



OST project nomination for PECI:

**Closing the 400 kV Albanian internal  
transmission network ring**

## Why?

- The internal 400 kV transmission network does not form a ring configuration and has a longitudinal profile;
- Outage of every internal 400 kV line separates the network in two parts connected through the 220 kV grid, violating the security criteria for the existing configuration;
- Closing the 400 kV ring will avoid bottlenecks in the internal grid and increase the cross-border energy flows and transmission capacity;
- Rate of applications for RES development in affected Project area currently exceeding 1.5 GW of generating capacity;
- This project has been identified from the Masterplan of the Albanian Transmission Network development as a priority investment for OST needs in the mid term time horizon.



This Project includes the following investment components:

- Construction of a new 400 kV transmission line between Fier and Rrashbull substations – about 78 km long with ACSR 2x490/65 mm<sup>2</sup> conductor
- Extension of 400 kV Fier substation
- Extension and reinforcement of Rrashbull substation
- Conversion works at Tirana-2 substation in order to be able to operate one circuit of the new 220 kV double circuit line Tirana 2 – Rashbull at 400 kV

- 
- It should be noted that the project of a double circuit 220 kV transmission line between Tirana2 – Rrashbull currently in implementation phase will have two 220 kV circuits.
  - Its perspective is to upgrade the second circuit to 400 kV once this Project is implemented.
  - The need for a new 400 kV line Tirana 2 – Rrashbull is therefore eliminated.

Important consideration → This Project provides increased value to existing transmission projects currently in implementation.

Perspective 400 kV Internal  
Transmission Ring →

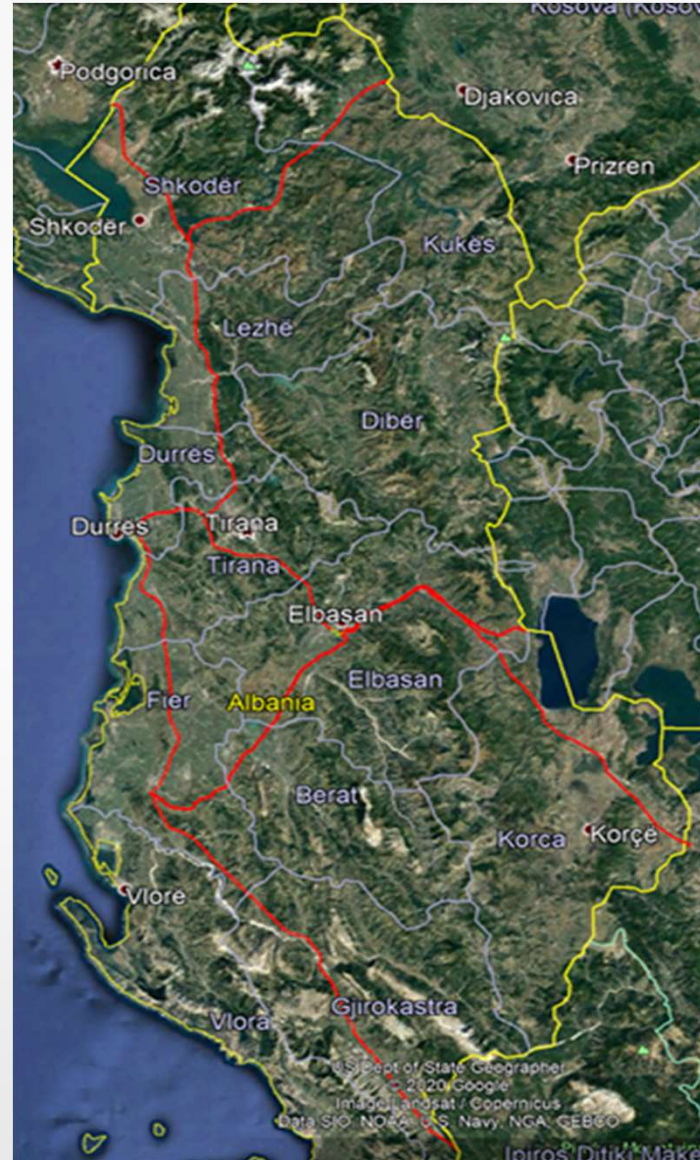



## Benefits of this Project:

- increases the safety of electrical energy supply of the overall transmission grid;
- enables to meet the N-1 operational safety criteria for various operating regimes;
- aims the gradual strengthening of the role of the 400 kV network as the main corridor for the transmission of energy in the North-South direction and vice versa,
- decreases the role of the existing and ageing 220 kV transmission corridor between Fier and Rrashbull;

## Benefits of this Project:

- accommodates the grid integration of large amounts of variable renewable energy sources;
- enhances the importance of 400/220 kV Fier substation as a major hub connecting large number of photovoltaic power plants and overall RES generating capacity;
- connects to the 400 kV grid the Durres area, representing a major electrical load center as well as important economical, touristic and marine region;
- avoids possible bottlenecks in the existing longitudinal 400 kV grid, paving the way for increased transmission capacity with bordering countries;

## Important aspects:

- Closing the internal 400 kV transmission ring is **essential for the development of every future interconnection project** of Albania.
- The ring configuration includes all 400 kV substations to which all existing 400 kV interconnections are connected such as SS Tirana2 (400 kV interconnection to Montenegro and to Kosova through SS Koman) and SS Elbasan2 (400 kV interconnection to North Macedonia and to Greece through SS Zemblak).
- The new 400 kV ring will enable the new 400 kV interconnection between SS Fier and Arachtos (Greece) as well as the development of the new HVDC submarine cable with Italy.



# Planned Ring configuration of 400 kV transmission grid

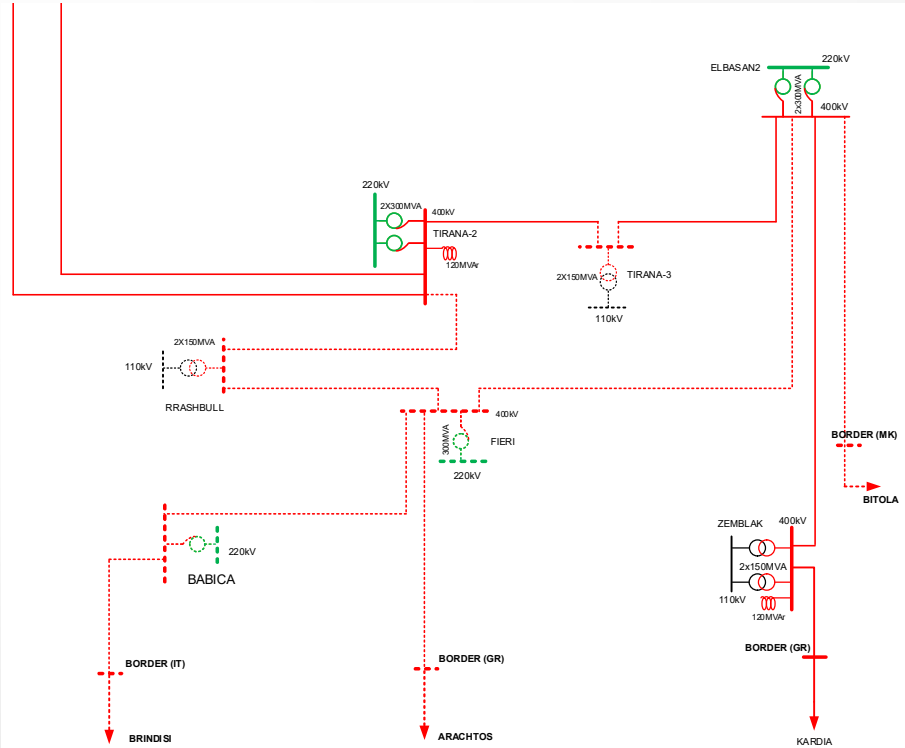
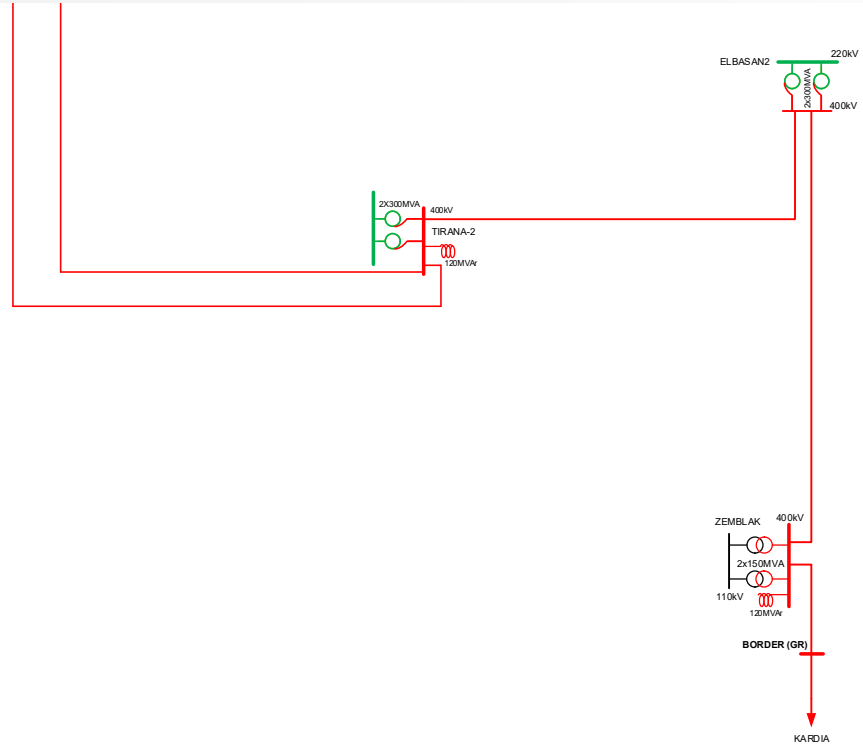



The preliminary cost estimate of the Project is around €31 million.

This project was previously applied to WBIF for a grant for technical assistance in cooperation with KfW as the main financial institution.

Its application was supported by the Strategic Planning Committee and it is planned to reapply in the upcoming future WBIF round for technical assistance for feasibility and environmental impact studies.

Expected time schedule for construction: 2030



Thank you!