



Electricity Balancing

Alexander Kabinger

TAIEX Kick-off 4.4.2023

14.00-15.00	Electricity Balancing – Block 1 <ul style="list-style-type: none">- General framework- Procurement and exchange of balancing energy via European balancing platforms- Q & A	Alexander Kabinger, E-Control
15.00-15.15	Coffee break	
15.15-16.15	Electricity Balancing – Block 2 <ul style="list-style-type: none">- Procurement of balancing capacity- Allocation of cross-zonal capacity- Settlement, esp. Imbalance Settlement- Q & A	Alexander Kabinger, E-Control

- Electricity Regulation (EU) 2019/943
 - Balance responsibility (Art 5)
 - Balancing market (Art 6)
 - Additional RCC tasks related to balancing (Art 37 par 1 lit j and k)
 - Regional sizing of reserves
 - Facilitation of balancing capacity procurement
 - ...
- Electricity Directive (EU) 2019/944
 - e.g. Art 17 (Demand response through aggregation), Art 40 (TSO responsibilities)
- Regulation establishing a guideline on electricity balancing (EU) 2017/2195 - EBGL
 - Direct requirements
 - terms and conditions or methodologies

Balancing → market side of things, LOAD-FREQUENCY CONTROL AND RESERVES → System operation guideline

Electricity Balancing Guideline (EBGL) aims at integrating balancing markets of the EU



COMMISSION REGULATION (EU) 2017/2195 of 23 November 2017 establishing a **guideline on electricity balancing**

- Functions and responsibilities of TSOs, BRPs, BSPs,
- Cross-border exchange of balancing energy (aFRR, mFRR, RR) via platforms and IN-platform
- Settlement (TSO-BSP, TSO-BRP, TSO-TSO)
- Harmonisation of many balancing related topics (eg. calculation of imbalance prices)
- Rules for exchange of balancing capacity
- ...

‘balancing’ means all actions and processes, on all timelines, through which TSOs ensure, in a continuous way, the maintenance of system frequency within a predefined stability range as set out in Article 127 of Regulation (EU) 2017/1485, and compliance with the amount of reserves needed with respect to the required quality, as set out in Part IV Title V, Title VI and Title VII of Regulation (EU) 2017/1485;

balancing services

balancing energy

‘balancing energy’ means energy used by TSOs to perform balancing and provided by a balancing service provider

European platforms for the exchange of standard products for balancing energy

balancing capacity

‘balancing capacity’ means a volume of reserve capacity that a balancing service provider has agreed to hold and in respect to which the balancing service provider has agreed to submit bids for a corresponding volume of balancing energy to the TSO for the duration of the contract

TSOs may exchange standard balancing capacity products

Overview terms and conditions or methodologies EBGL

Art 5	Balancing Capacity	Balancing Energy	Other
European Not yet decided Not mandatory	<ul style="list-style-type: none"> Standard products BC Co-optimisation Harmonisation CZCA 	<ul style="list-style-type: none"> Implementation framework aFRR (incl standard product) Implementation framework mFRR (incl standard product) Implementation framework IN Pricing TSO-TSO settlement classification of activation purpose assessment of limitation of forwarded bids 	<ul style="list-style-type: none"> Imbalance Settlement harmonisation
Regional	<ul style="list-style-type: none"> Rules and processes for exchange of BC + balancing algorithm Exemption from transfer of BC by BSPs Probabilistic CZC for exchange of BC Application of CZCA method Market Based CZCA method Economic Efficiency CZCA method 	<ul style="list-style-type: none"> IF RR TSO-BSP model settlement $k\Delta f$ and ramping within SA settlement $k\Delta f$ and between SA Settlement of unintened exchange within SA Settlement of unintened exchange between SA Capacity Calculation 	<ul style="list-style-type: none"> Exemption imbalance settlement period
National	<ul style="list-style-type: none"> Specific products Exemption separate procurement upwad/downward Additional settlement mechanism BC 	<ul style="list-style-type: none"> Specific products Limitation of forwarded bids 	<ul style="list-style-type: none"> Exemption publication of prices Allocation DSO costs Terms and conditions for BSPS and BRPs Derogations (Costs)

Terms and conditions related to balancing

Art 18 EBGL

- National terms and conditions developed by national TSOs, approved by competent NRA
 - terms and conditions for balancing service providers
 - terms and conditions for balance responsible parties

Important way to implement requirements on national level

- > TSO-TSO model
 - procurement by each connecting TSO
- > Usage of standard products
 - Products defined in Implementation frameworks
 - Specific products need to be approved, demonstration of necessity, review every 2 years, only local
- > Common Merit Order Lists
 - Locally collected bids are transferred to the platforms and organised in common merit order lists
 - Common optimization for all TSO demands respecting cross border capacities
 - Possibility to restrict transfer of local bids to CMOL if there is a local intraday market with gate closure time after balancing energy gate closure time
- > Separate markets for balancing energy and balancing capacity
 - Balancing capacity bids shall not determine prices of balancing energy bids
 - Bids in the balancing energy procurement do not need to be connected to balancing capacity bids (free bids)
- > Usage of marginal pricing rule
 - for aFRR determined every few seconds, each time a new optimisation is run

- **aFRR**: implementation project PICASSO (**P**latform for the **I**nternational **C**oordination of **A**utomated Frequency Restoration and **S**table **S**ystem **O**peration)
 - Go live/cross-border exchange since 22.6.2022
- **mFRR**: implementation project MARI (**M**anually **A**ctivated **R**eserves Initiative)
 - Go live/cross-border exchange since 5.10.2022
- **RR**: implementation project TERRE (**T**rans **E**uropean **R**eplacement **R**eserves **E**xchange)
 - Go live/cross-border exchange since 29.9.2020
- **IN**: implementation project IN-Platform (sucessor of IGCC)
 - Go live/cross-border exchange since 24.6.2021, IGCC since 2011

Full Activation Time (FAT)

- Not harmonize in the beginning but interchange profile has a FAT of 7.5 min. By December 2024, the FAT is **harmonized to 5 minutes**

Minimum bid size and granularity

- **harmonized to 1MW**

Validity Period

- **harmonized to 15 minutes**

Bid Divisibility

- all aFRR standard bids are **divisible**

Complex Bids

- Complex Bids/Linked bids are not supported by the aFRR platform

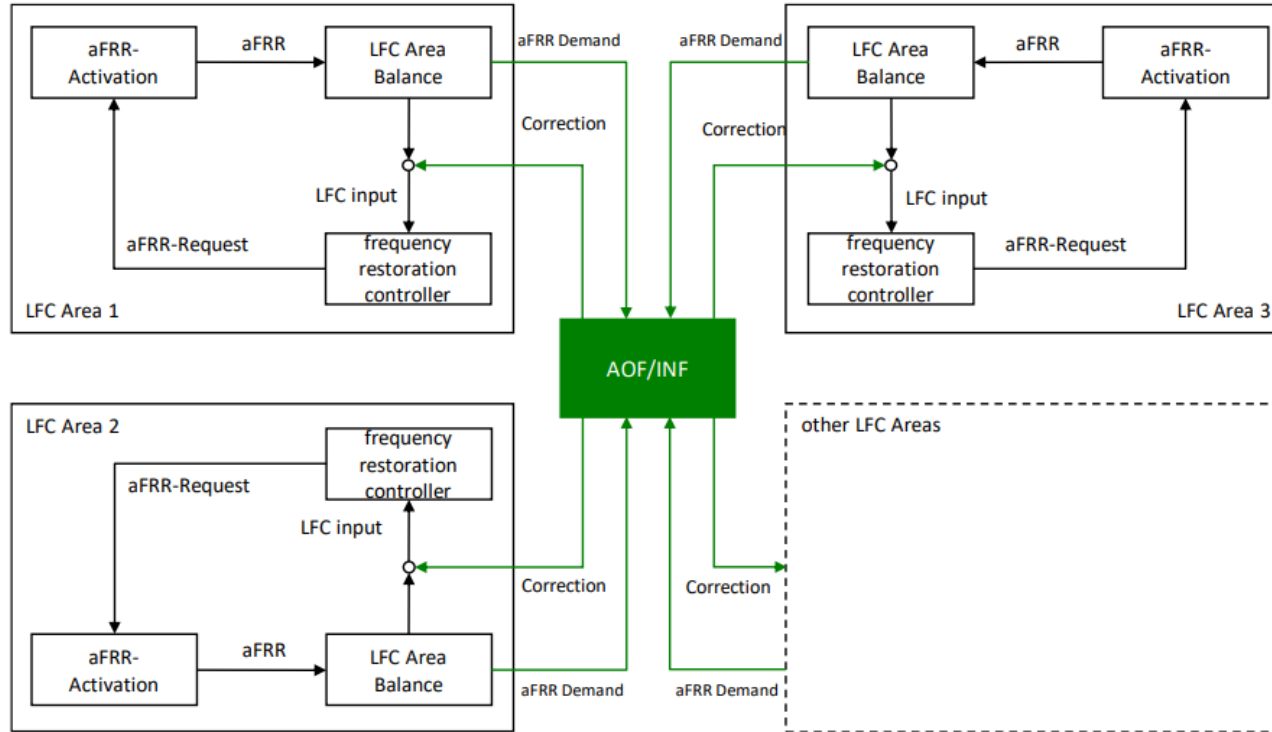

Optimisation cycle of 4 sec leading to market time unit in same resolution (new price for every MTU)

Implicit netting of demands of PICASSO participants

Imbalance netting of others in separate layer

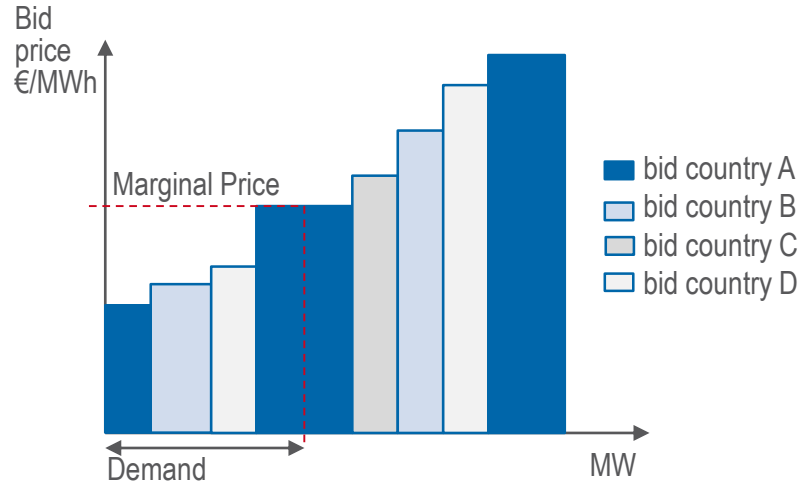

Pricing for balancing energy based on marginal pricing (pay-as-cleared).

Marginal Price represents the price of the highest price bid of a standard product which has been selected to cover the energy need for balancing purposes within a specified area. The AOF computes the balancing energy price per LFC area.

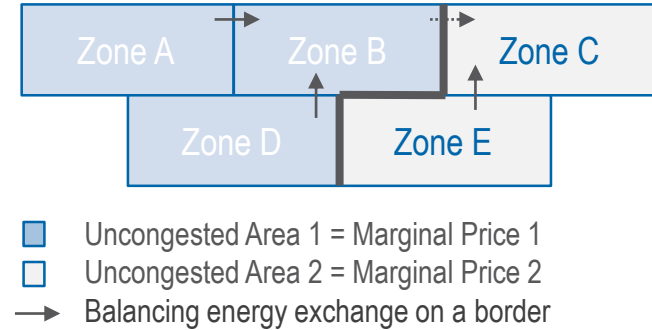

In case there is no congestions between adjacent areas, the price will be the same in these areas

In case there is a congestion – there will be a price split (principally like the day-ahead market)

Prices per market time unit (=optimisation cycle AOF)

Acession roadmap for PICASSO

accession roadmap for the aFRR- Platform (25 October 2022)

source:
https://www.entsoe.eu/network_codes/eb/picasso/

Country	Derogation deadline	TSO	2022												2023				2024							
			7	8	9	10	11	12	1	2	3	4	5	6	Q3	Q4	Q1	Q2	Q3	Q4						
EU:																										
Austria		APG	[Green]																							
Belgium ¹	24.07.2024	Elia	[Yellow]																							
Bulgaria	30.06.2024	ESO	[Green]																							
Croatia	24.07.2024	HOPS	[Green]																							
Czech republic		CEPS	[Green]																							
Denmark ²	24.07.2024	Energinet	[Yellow]																							
Finland ²	24.07.2024	Fingrid	[Green]																							
France	24.07.2024	RTE	[Yellow]																							
Germany		50HzAMP,TNG,TTG	[Green]																							
Greece	24.07.2024	ADMIE	[Yellow]																							
Hungary	24.07.2024	MAVIR	[Yellow]																							
Italy	24.07.2023	Terna	[Green]																							
Netherlands ³	24.07.2024	Tennet BV	[Yellow]																							
Poland	24.07.2024	PSE	[Yellow]																							
Portugal		REN	[Green]																							
Romania	01.10.2023	Transelectrica	[Yellow]																							
Slovakia	24.07.2024	SEPS	[Yellow]																							
Slovenia		ELES	[Green]																							
Spain	24.07.2024	REE	[Yellow]																							
Sweden ²	24.07.2024	SVK	[Yellow]																							
EEA:																										
Norway ²	24.07.2024	Statnett	[Yellow]																							
Non-EU:																										
Switzerland ⁴		Swissgrid	[Green]																							
		5.4.(b)(i)	[Yellow]																							
		5.4.(b)(i)	[Light Green]																							
		5.4.(b)(iii)	[Green]																							
		5.4.(b)(v)	[Green]																							
		5.4.(b)(vii)	[Red]																							

National terms and conditions development
 National terms and conditions entry into force
 Interoperability tests between TSO and aFRR-Platform
 TSO connection to aFRR-platform / Go-live
 EBGL Article 62 Derogation considered (no deadline listed) / requested (no deadline listed) / granted (new deadline listed)

Full Activation Time (FAT)

- 12,5 minutes

Minimum bid size and granularity

- 1MW

Validity Period

- 15 minutes

Bid Divisibility

- (Fully) divisible bids
- Indivisible bids

Complex Bids

- Conditional / technical linking
- Exclusive group, Multipart bids

Scheduled activation OR direct Activation

- BSP's may choose if their bids are available for Direct Activation
- Scheduled Activation will be run every 15 minutes, once for each quarter hour throughout the day, with delivery for the next full quarter hour.
- Direct Activation will run on-demand, with delivery from the remainder of one quarter hour and to the end of the subsequent quarter hour.

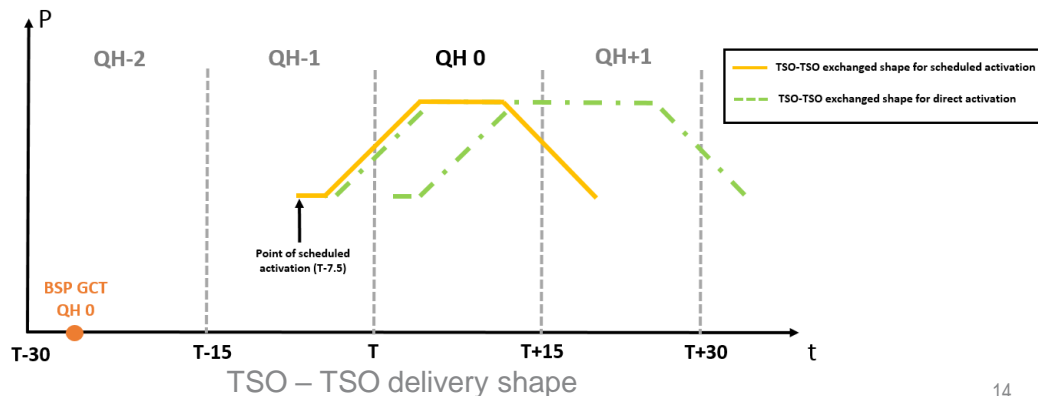

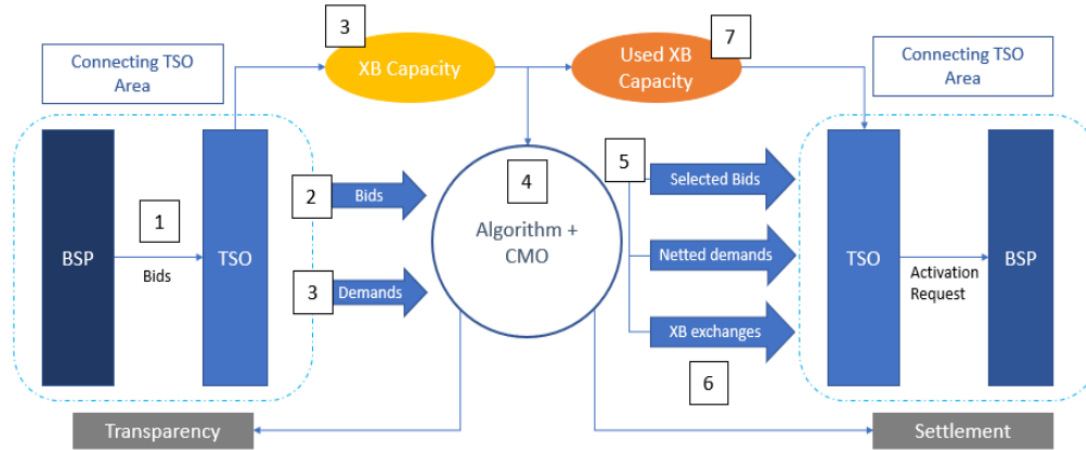

Source: MARI Activation Optimization Function Public Description

1. TSO receive bids from BSPs in local market balance area
2. Forward of coherent mFRR balancing products to mFRR platform
3. TSOs communicate their balancing demands and the available XB transmission capacities (ATC)
4. Optimization of the clearing of balancing demands against BSPs bids
5. Communication of the accepted bids, satisfied demands, and prices
6. Calculation of the commercial flow between market balancing areas and settlement of the expenditure and revenues between TSOs
7. The resulting XB schedules and remaining ATC are sent to the TSOs

- **Cross border marginal pricing** is the general principle
- For scheduled activation, **the CBMP is equal to the most expensive** activated bids (additional rules for case of price indeterminacy)
- For direct activations, there are **two CBMPs for both quarter hours** affected by the direct activation
 - QH1: maximum from all direct activations in QH1 and the SA QH1
 - QH2: maximum from all direct activations in QH1 and the SA QH2

Accession roadmap for MARI

accession roadmap for the mFRR-Platform (29 October 2021)

source:
https://www.entsoe.eu/network_codes/eb/mari/

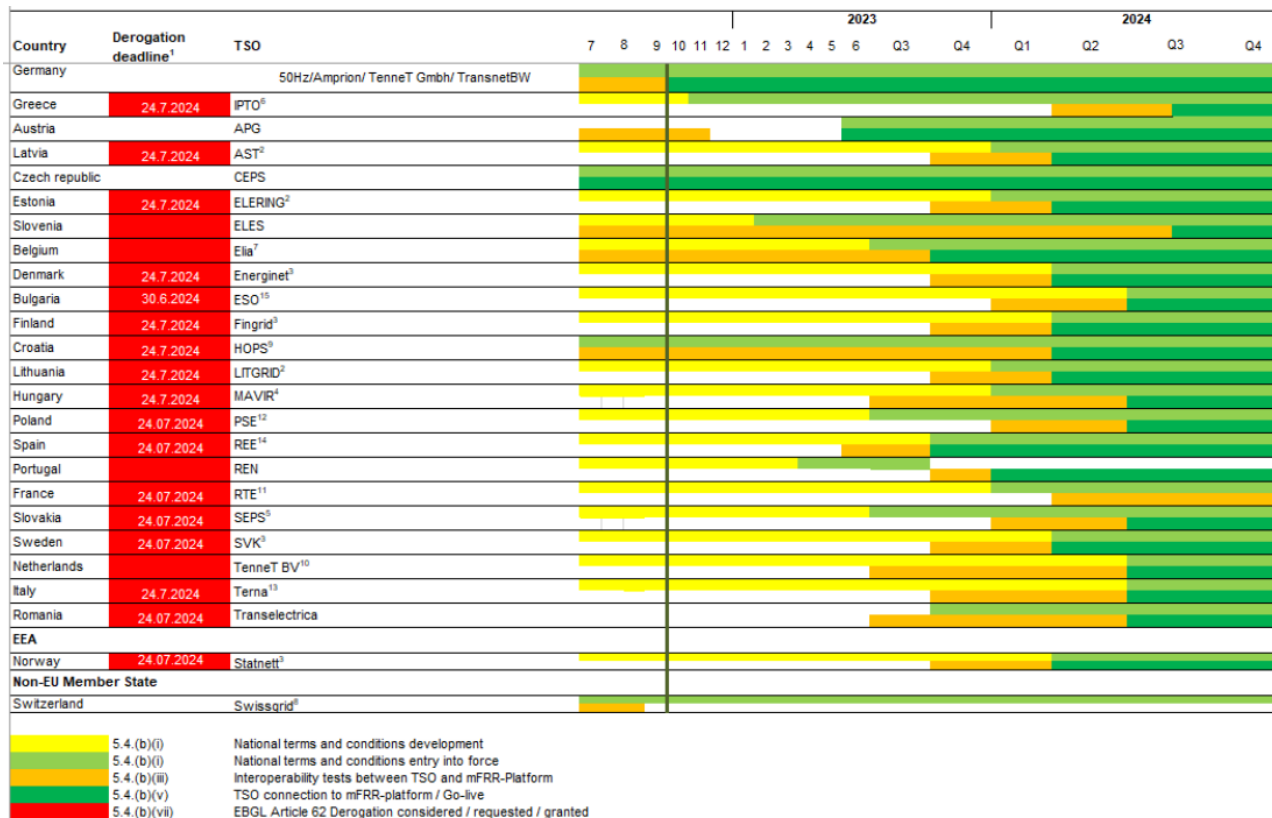

- Regional platform of TSOs using RR
- 1 hour delivery products – to be shortened
- BSP GCT H-55
- Complex bids
- Elastic needs of TSOs

https://www.entsoe.eu/network_codes/eb/terre/

TERRE Members (7 TSOs)	
Czech Republic	
France	
Italy	
Poland	
Portugal	
Spain	
Switzerland	
TERRE Observers (1 TSO + ENTSO-E)	
Hungary	
ENTSO-E	
Project Members (3 TSOs)	
Germany	
Norway	
Sweden	

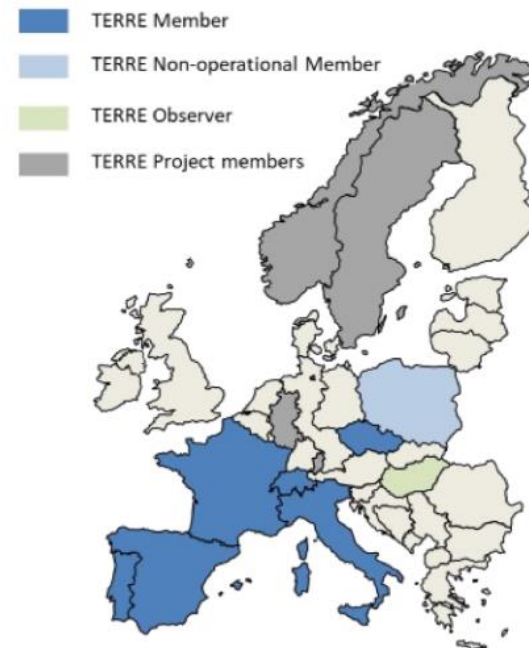

TERRE members (As of June 2022)

cross-zonal capacity calculation within the balancing timeframe

- Regional methodologies have been handed in, not yet approved (planned mid 2023)
- Before the implementation of the capacity calculation methodology pursuant to paragraph 3, TSOs shall use the cross-zonal capacity remaining after the intraday cross-zonal gate closure time.
- All balancing platforms use CZC, capacity management function (overarching function of platforms) to ensure updates

- Market based
- Short term procurement
- Separate procurement of upwards and downwards balancing capacity (exemption possible)
- Contracts for balancing capacity shall not be concluded more than one day before the provision, contracting period not longer than one day (exemption possible – thresholds have to be respected)

See Art 32 EBGL and Art 6 Electricity Directive

EBGL foresees possibilities for the exchange of standard balancing capacity products or sharing of reserves

- exchange/sharing of balancing capacity is not mandatory
- TSOs can agree to do so, NRA approval is necessary
- to exchange/share balancing capacity it is necessary to allocate cross zonal capacity (CZC) or use a methodology for calculating the probability of available cross-zonal capacity after intraday cross-zonal gate closure time
- For the allocation of CZC one of three methods foreseen in the EBGL needs to be used to ensure optimal usage of CZC for balancing capacity on the one side and for the energy market on the other side
 - Co-Optimization
 - Market Based Methodology
 - Economic Efficiency Methodology
- Co-optimization is a all TSOs methodology, the other ones are regional (CCR) ones – later to be harmonised
- Limits on usage depending on methodology and time of contracting

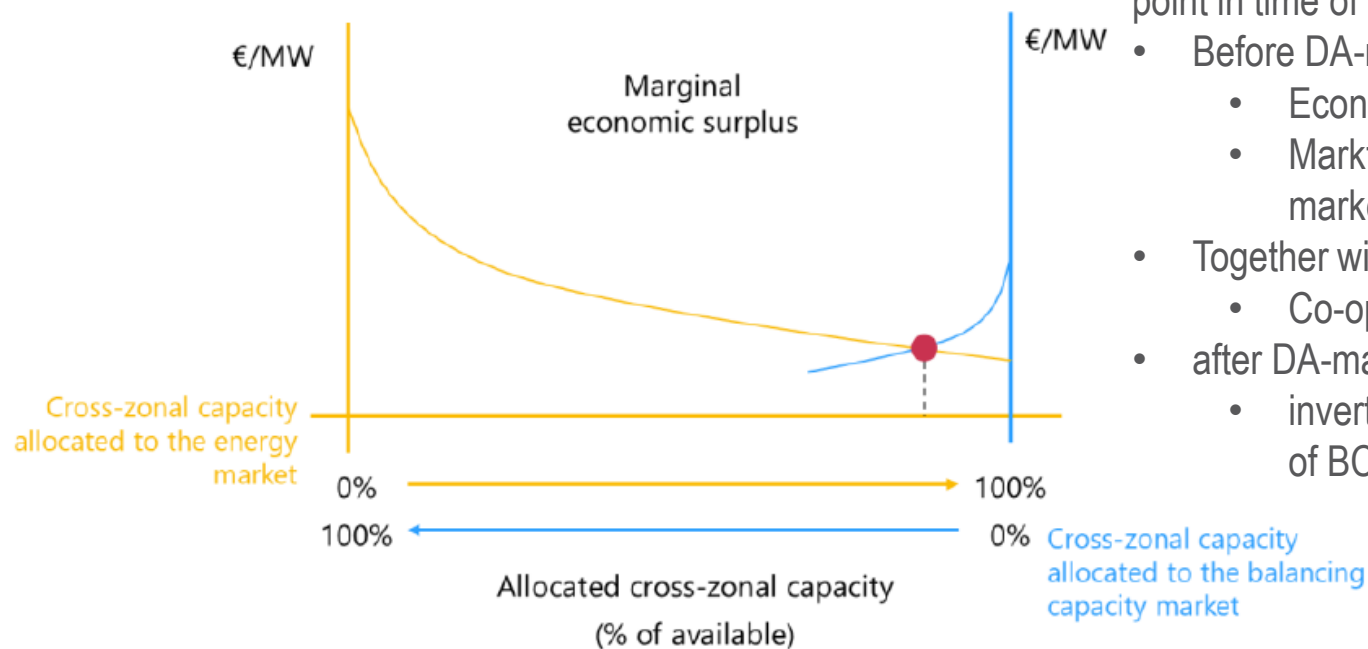

point in time of balancing capacity market:

- Before DA-market:
 - Economic efficiency
 - Market based - forecast of DA market is needed
- Together with DA-market
 - Co-optimisation
- after DA-market:
 - inverted market-based – forecast of BC market needed

Harmonised methodology for the allocation of CZC for the exchange of BC or sharing of reserves

- Art 38(3) EBGL
- Harmonised methodology was developed by TSOs and is to be decided by ACER mid 2023
 - Public consultation in April

Types of settlement and general principles (Art 44)

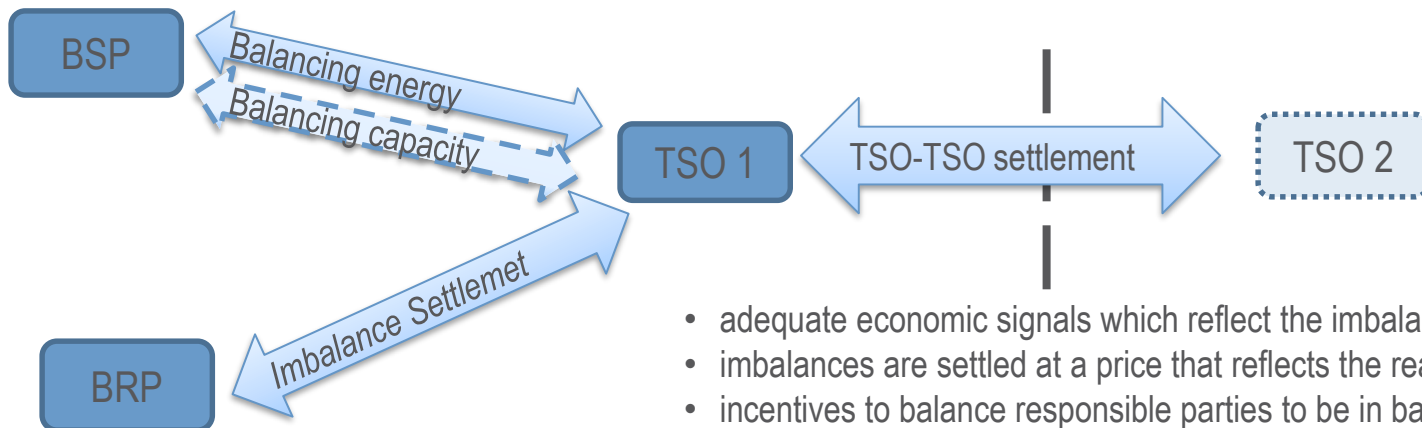

Art 44(3): Possibility to introduce “additional settlement mechanism” to settle costs of BC and other costs with BRPs, preferably with “shortage pricing function”

- adequate economic signals which reflect the imbalance situation
- imbalances are settled at a price that reflects the real time value of energy
- incentives to balance responsible parties to be in balance or help the system to restore its balance
- facilitate harmonisation of imbalance settlement mechanisms
- provide incentives to TSOs to fulfil their obligations pursuant SO
- avoid distorting incentives to BRPs, BSPs and TSOs
- support competition among market participants
- provide incentives to balancing service providers to offer and deliver balancing services to the connecting TSO
- ensure the financial neutrality of all TSOs.

- 15 minutes imbalances settlement period
- Imbalance price is mainly determined by price of activated balancing energy (not costs)
 - Weighted average of prices of activated balancing energy or maximum of balancing energy prices
 - value of avoided activation for cases of no activations
- General rule is single pricing, but dual pricing allowed under certain conditions and with justification
 - In specific ISPs, e.g. in case of almost balanced imbalance area
 - for all ISPs. e.g. ISP longer than 30 min
- Possibility to introduce additional components
 - a. scarcity component
 - e.g. add on in cases of great imbalances
 - b. incentivising component
 - e.g. ID-price index as lower bound of imbalance price
 - c. component related to the financial neutrality of the connecting TSO

ALEXANDER KABINGER



+43 1 24724 514



Alexander.kabinger@e-control.at



www.e-control.at