



## **ERE-s recent Activities**

**ECRB Meeting**

**13-th April 2022**

M. Sc. E. E. Elton B. Radheshi  
Secretary General

# Power system key figures during last years

Albania in general is a net importer of electricity (20 – 30 % of its demand depending on inflows) and will continue in the near future with such assumption. Exception is made for 2010 with 0.7 TWh, 2018 with 0.9 TWh, net export and last year 0.6 TWh.

## 2021 figures

- Export ~ 0.6 TWh
- Generation ~ 9.0 TWh
- Demand ~ 8.4 TWh

Even last year was a very good year for generation the sector suffered financially due to the high prices of imports during Q2 when we were obliged to import due to lack of reserve in hydro (net balance exp/imp 2.8/2.3 TWh).

The import – export chart in the figure clearly shows the electricity balance since 2009 up to 2021.

Reliability to Hydro and no diversification on generation has hampered the fluctuation of imports/exports.

We also had a increase of demand mainly due to the opening of the economy after Covid-19.

## Generation during last years vs. average in GWh

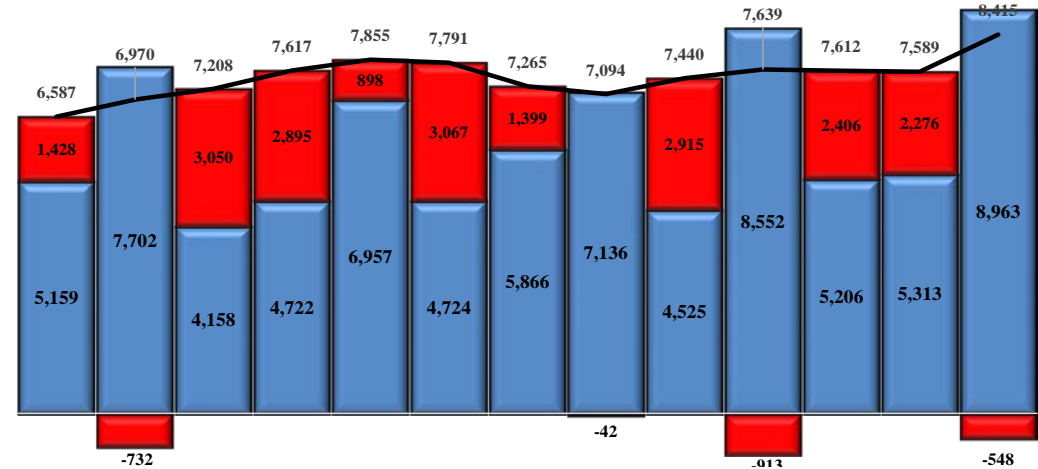

## Import – export from 2009

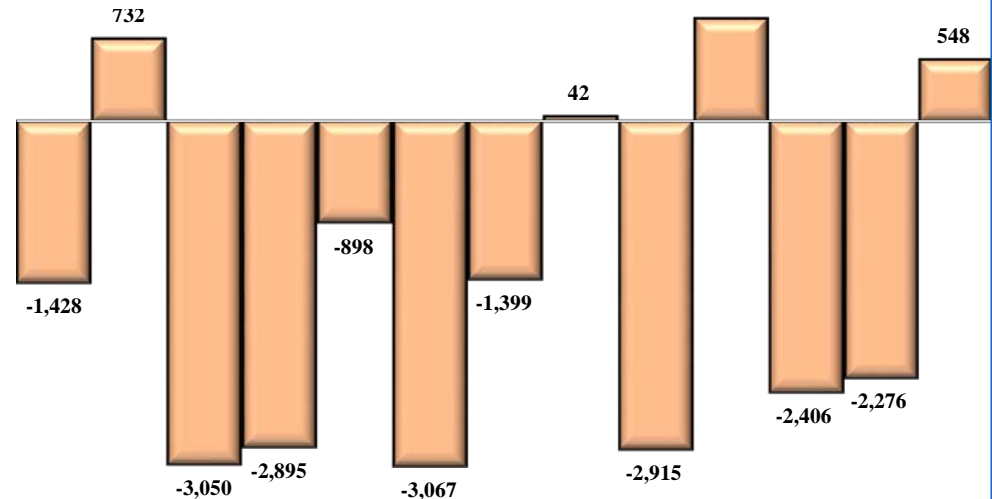

	2009	2010	2011	2012	2013	2014	2015	2016	2017	2018	2019	2020	2021
Imp/Eksp (GWh)	-1,428	732	-3,050	-2,895	-898	-3,067	-1,399	42	-2,915	913	-2,406	-2,276	548

# Power Transmission figures

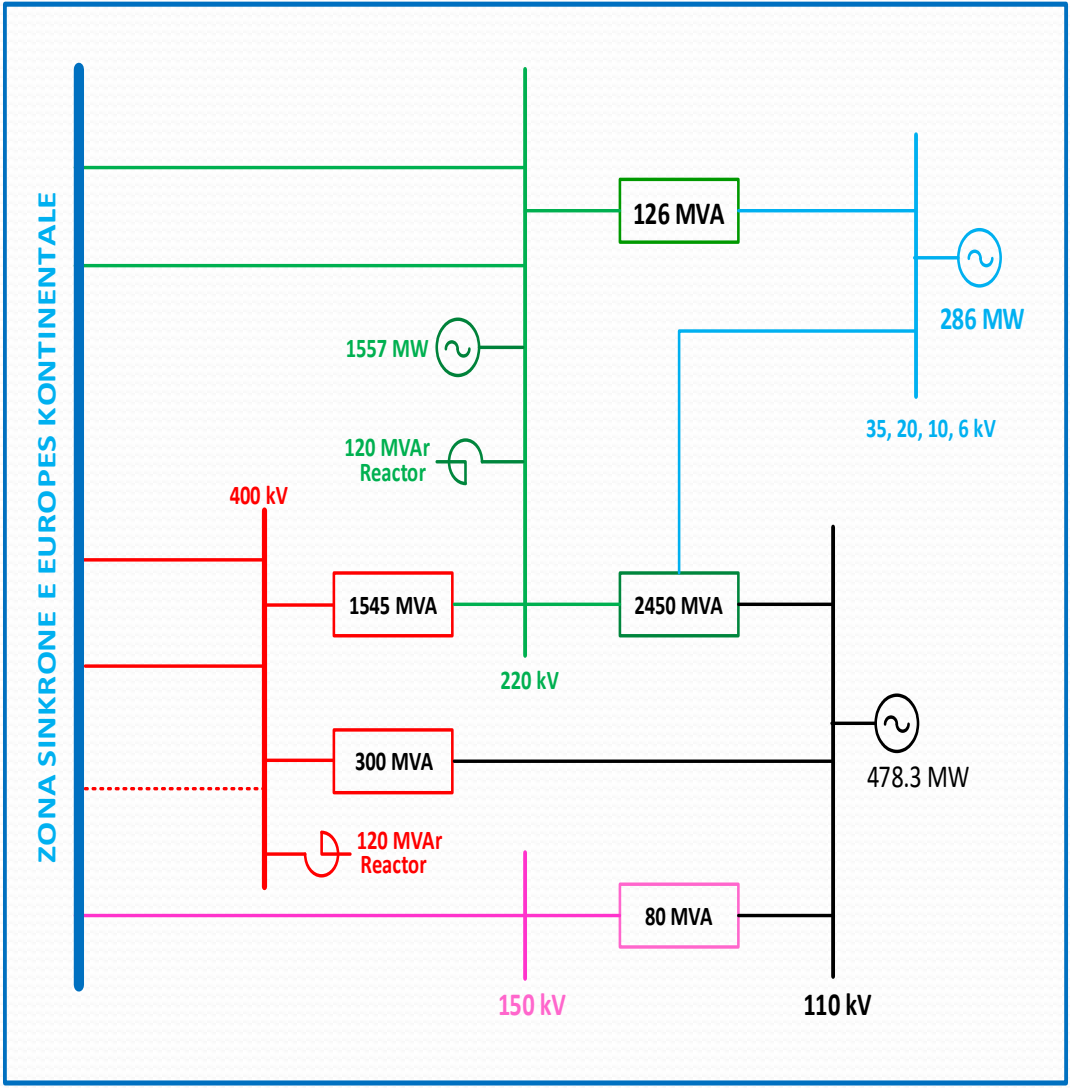
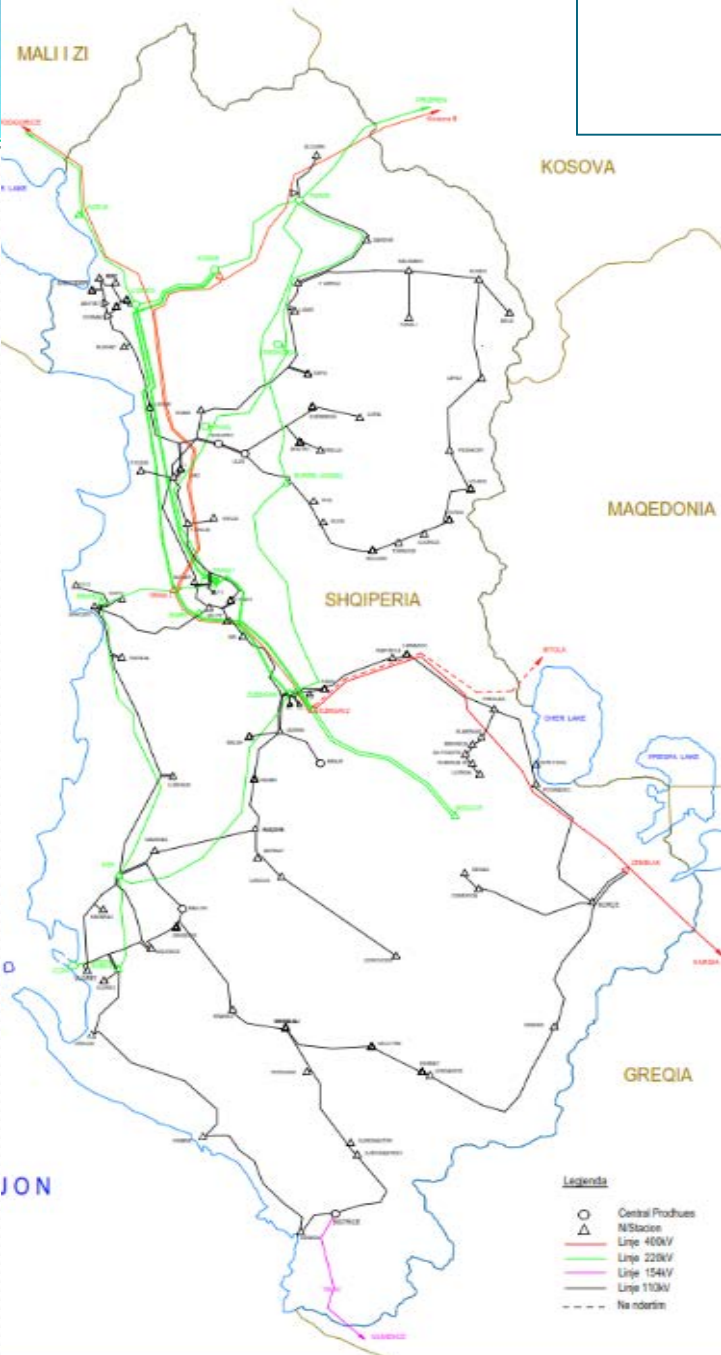

## Consumption in GWh 2004 - 2021

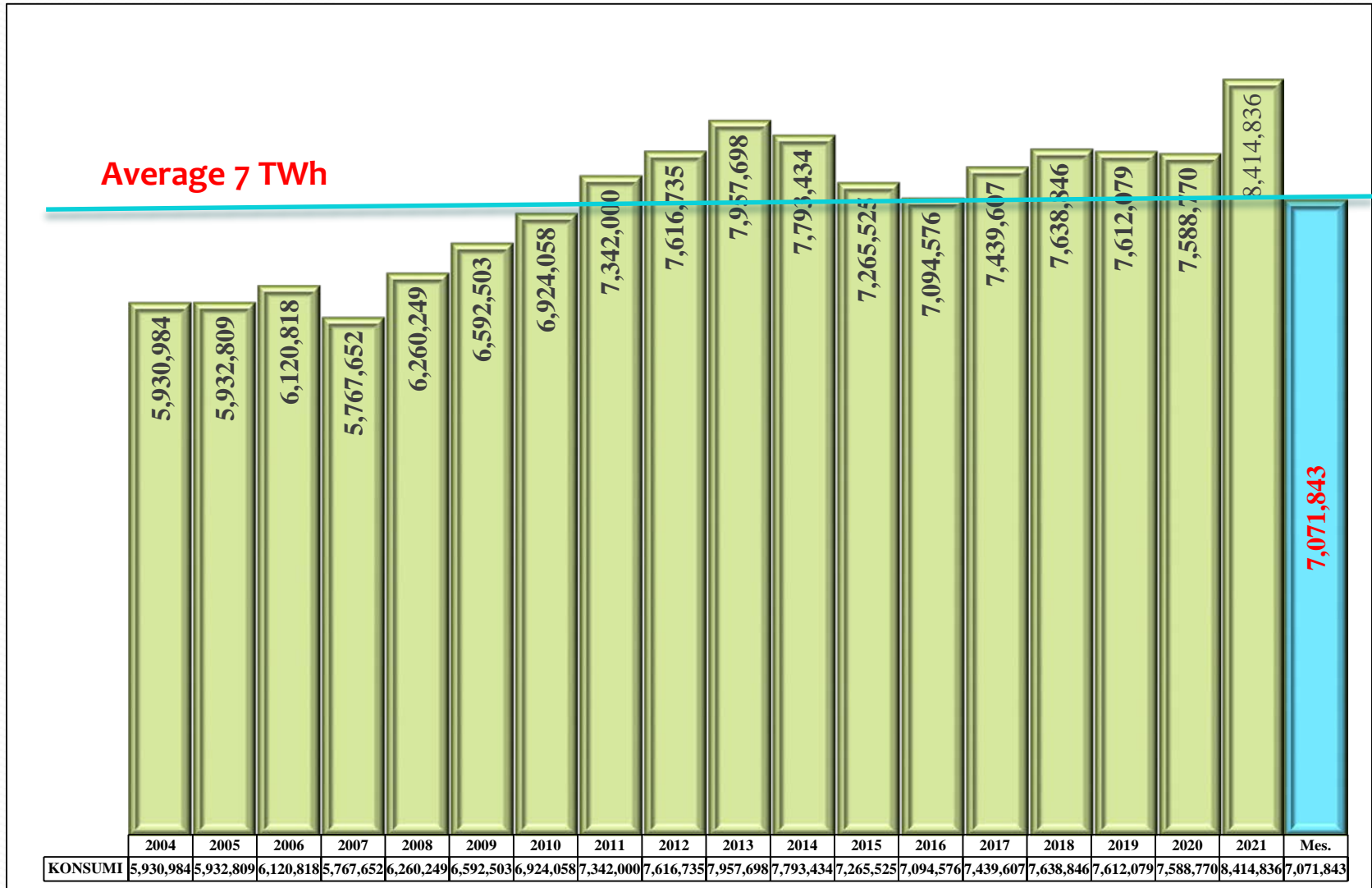

KONSUMI	5,930,984	5,932,809	6,120,818	5,767,652	6,260,249	6,592,503	6,924,058	7,342,000	7,616,735	7,957,698	7,793,434	7,265,525	7,094,576	7,439,607	7,638,846	7,612,079	7,588,770	8,414,836	7,071,843
---------	-----------	-----------	-----------	-----------	-----------	-----------	-----------	-----------	-----------	-----------	-----------	-----------	-----------	-----------	-----------	-----------	-----------	-----------	-----------

## Consumption of Household on the overall total consumption

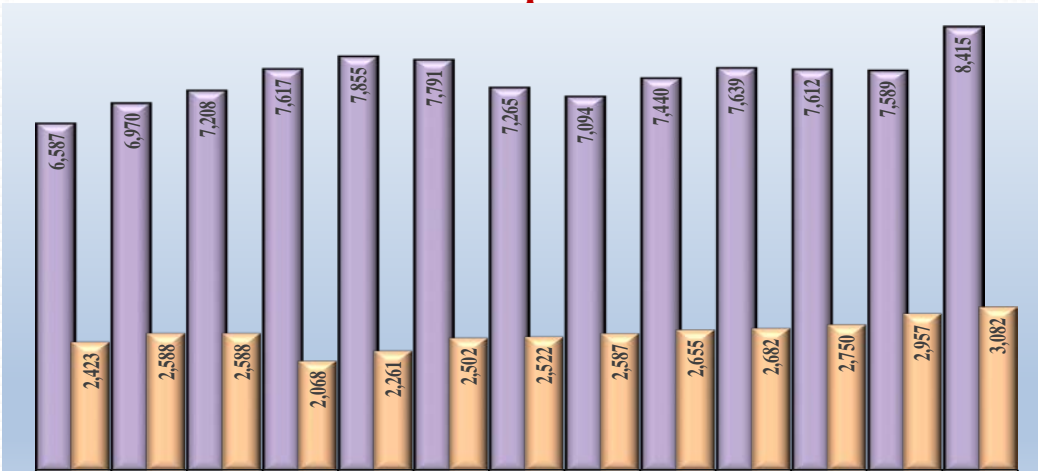

## Household represent around 52 % of the total billed consumption

SHPËRNDARJA E VLERËS SË FATURIMIT TË KLIENTËVE SIPAS KATEGORIVE (%)  
(faturimi total 66,375,633 000/Lekë)

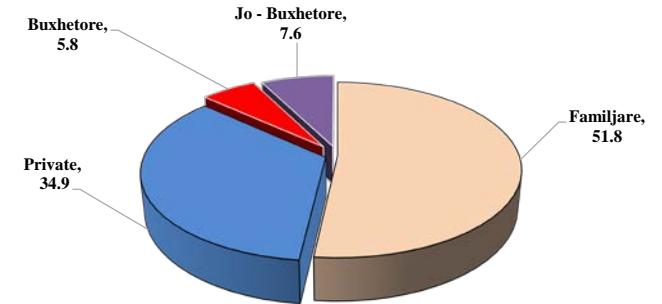

In 2021 there is a losses level of 20.62 %. There is a very slight decrease of losses level compared with 2020.

## Distribution losses in MWh

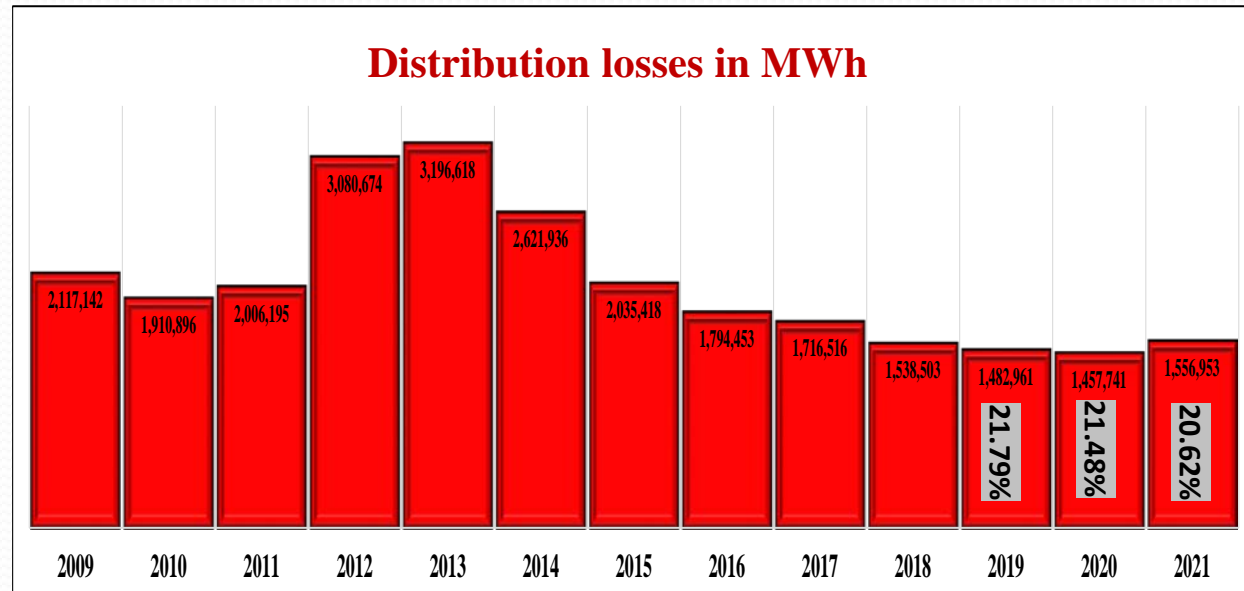

# Generation key figures during last 2 years 2018 - 2021

Albania is almost 100 % Hydro generation, small PV panel of 2 MW in total 20 MW are installed during last years.

Generation structure in 2021

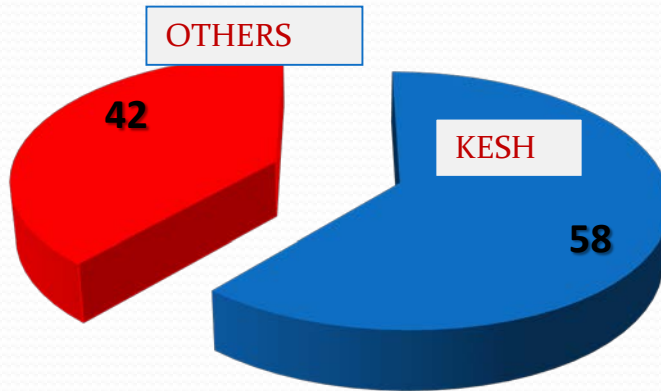

Small HPP – 905 MWh  
Small PV – 40 MWh

The share of the IPP in the generation structure is increasing year by year. Last year more than 90 MW of new capacity has been installed mainly small and medium HPP.

Installed capacity in MW in 2020

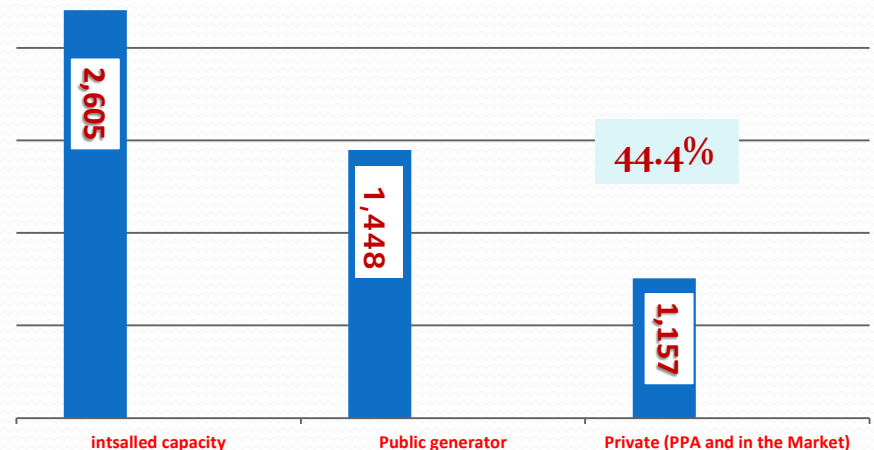

# Generation key figures during last years

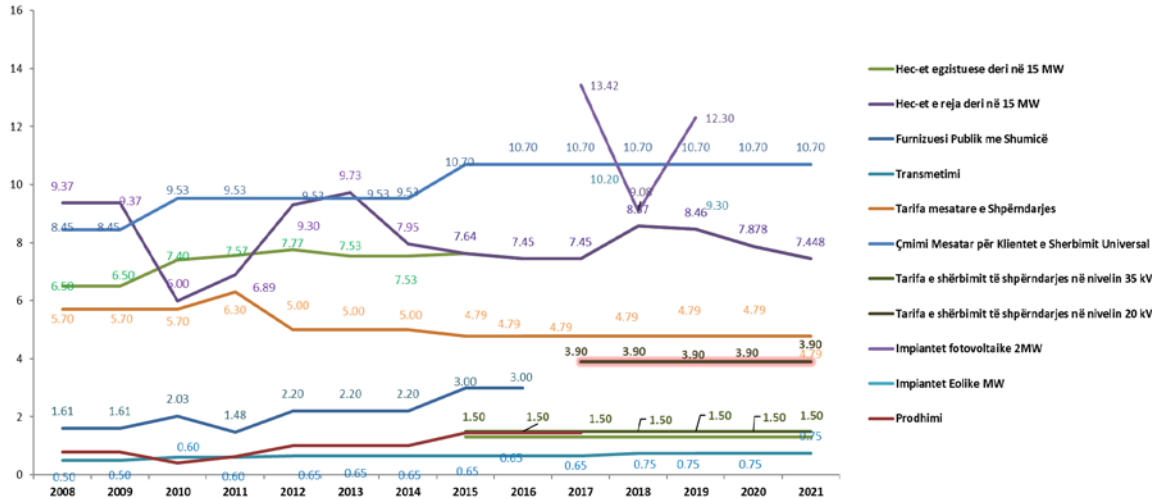

In Albania all the new generation plants from late 1991 are build under the concession scheme, BOT.

HPP under 15 MW have an off take contract with price which methodology is set by the Govt. and is based on the HUPX DAM price multiplied by an incentive coefficient.

This year price is set to 75 €/MWh.

An increase of production from IPP under 15 MW from 2017, is also noted.

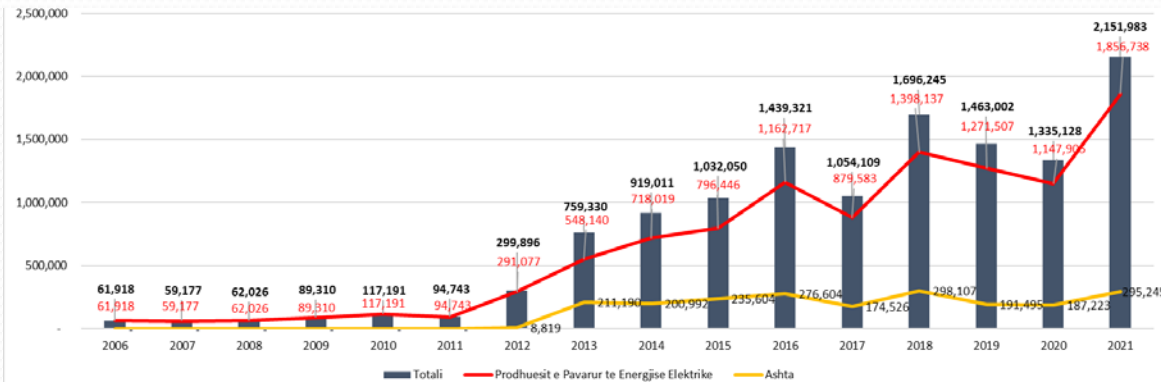

During 2020 we realized an auction for 140 MWp in PV panels in Karavasta area.

The first ranked bid had a price of 24.89 Euro/MWh.

50 % of the generation will be with off take contract with the supplier of last resort with offered price 24.89 €/MWh.

Other 50 % of the production will be in the free market.

The second auction was for a PV plant of 100 MWp with an auction price set at less than 30 €/MWh.

Both plants are under the process of authorizations and none of them have started constructions on site



## Amount in Mwh and and import prices in Euro by the Public utility during Years

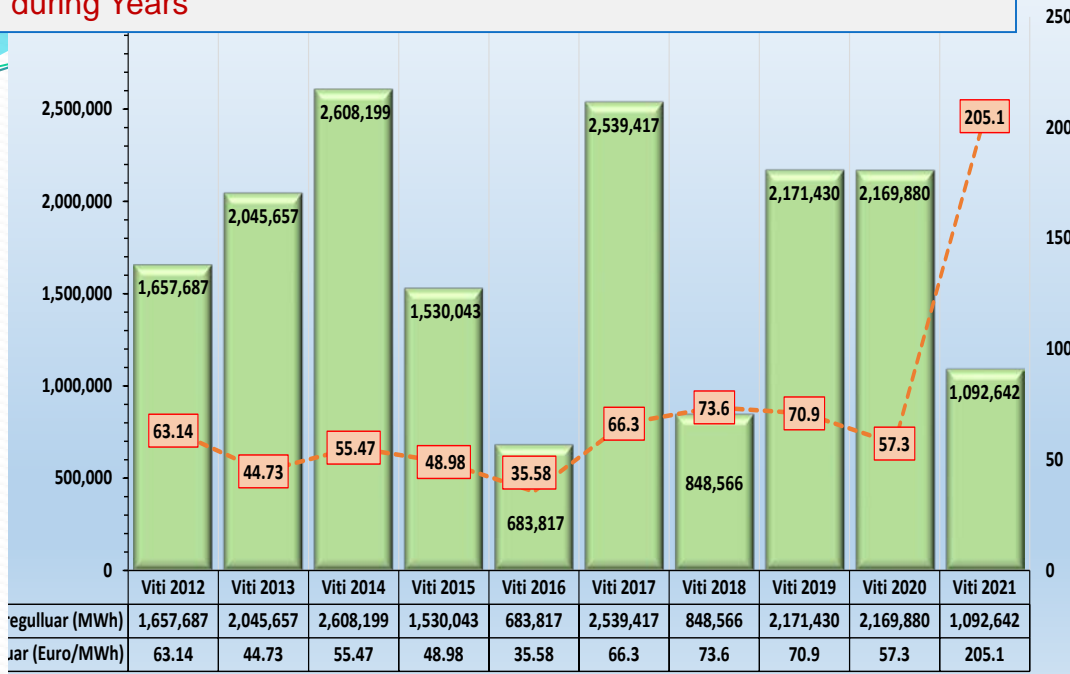

On the 8.10.2021, the Government of Albania declared a state of emergency effective until 15 April 2022,

On 22.10.2022 an emergency PSO act which dedicates all electricity produced by KESH to the universal supplier was adopted

The Government has also injected 100 million € for 2021, in the form of sovereign to guaranty the import of electricity with high prices,

As well as another 100 million € for Q1 2022.

Under the Decree the USS is serving the clients on the MV (20/10/6 kV) under low prices as Supplier of last resort for a period until July. Most probably this will be extended until the end of the year.

All customers in the HV and MV are “legally” deregulated from 1-st of January.

The balancing Market organised by the TSO in force from 1-st of April 2021 is functioning even prices went very high on the second half of the year. Some supplier faced financial problems anyhow we had no one which went on default.

ERE opened in March the auction for the Last resort Supplier which was not successful and will be reopened again for the moment the USS serves as LRS.

Both DSO and TSO has applied for a tariff increase the process is under approval from the regulator with projections of increase of the tariff for about 25% on both Operators.

## Consumption components for 2021

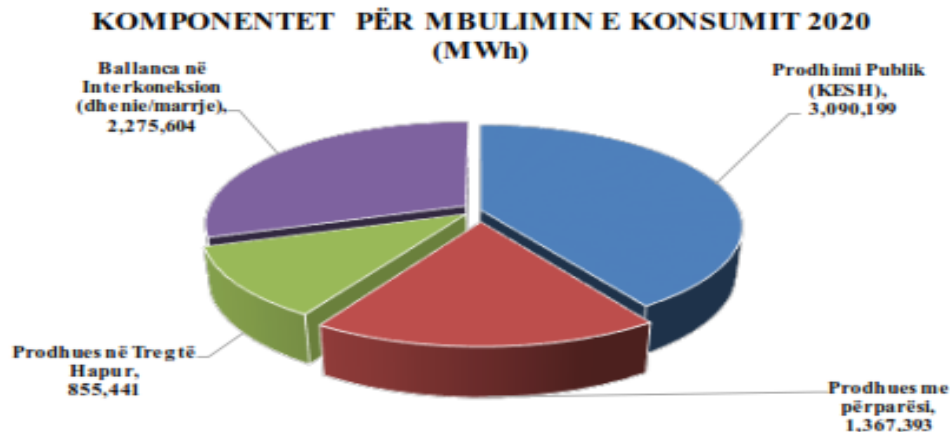



- **DSO unbounding undergoing. The two companies are operation separately as per their license since 2020 anyhow we do feel more should be done in this regard for the functional as well as operational unbounding of the DSO, the process of apointment of the CO unfderway**
- **Alpex has been established in 2020 and at the beginning of this year the contract with the service provider was signed. Plans for the DAM operational by the end of 202**
- **MC bwtween AI and Kosovo underway**
  - **In October the Regulators, TSO's and the PX has signed the Framework agreement which sets the rules for the operation of the PX in both countries**
  - **In December the Regulators has signed the MoU for the reciprocity of license recognition in both countries**
- **NEMO designation after the apply of the PX by Q3 (new Market rules under discussions with PX and TSO)**

**On the international relations we hold the Presidency of MEDREG and looking forward for collaboration with similar institutions after the opening due to COVID-19 measures.**



**Thank you for your  
attention!**

M. Sc. E. E. Elton B. Radheshi  
Secretary General  
ERE