



Energy Efficiency Coordination Group Workshop

Audits in the Industry

Vienna – 20. March 2018

Liliane CLOÂTRE

International Division Director Energy Services Coordination



AGENDA

- 1 The EDF Group
- 2 Energy Audits in the Industry and Regulation
- 3 The Energy Services within EDF
- 4 Audits in the Industry
- 5 Q/A

A world leading Energy company

- Électricité de France (EDF), one of the world's top five utilities, and the number-one nuclear operator, **is an integrated energy company** active in all businesses: generation, transmission, distribution, energy supply and trading, and energy services.
- The group has expertise in engineering and operation of power plants and networks, and in the design and promotion of **energy efficiency solutions**.
- The EDF Group is the **leader in the French and UK electricity markets, and has solid positions in numerous other European Countries (Italy, Belgium, etc.)**, as well as industrial operations or projects in more than 30 countries on five continents.
- The EDF Group is a **leader in low-carbon generation** especially in Europe in generation with Renewables.

EDF's key figures (2016)

- €71,2 billion Sales
- €16,4 billion EBITDA
- 37,1 million customers
- 154 845 employees worldwide
- 584,7 TWh Group electricity generation
- 88% Group carbon-free generation

(Direct emissions excluding the life cycle analysis of generating plant and fuel)

EDF Group Footprint

€16.4 billion EBITDA
- 4.8% organic change

€11.7 billion net investments⁽¹⁾

37.1 million customers
(32.5 million electricity and 4.6 million gas)

154,845 employees

88% carbon-free generation⁽²⁾

Installed capacity in GWe

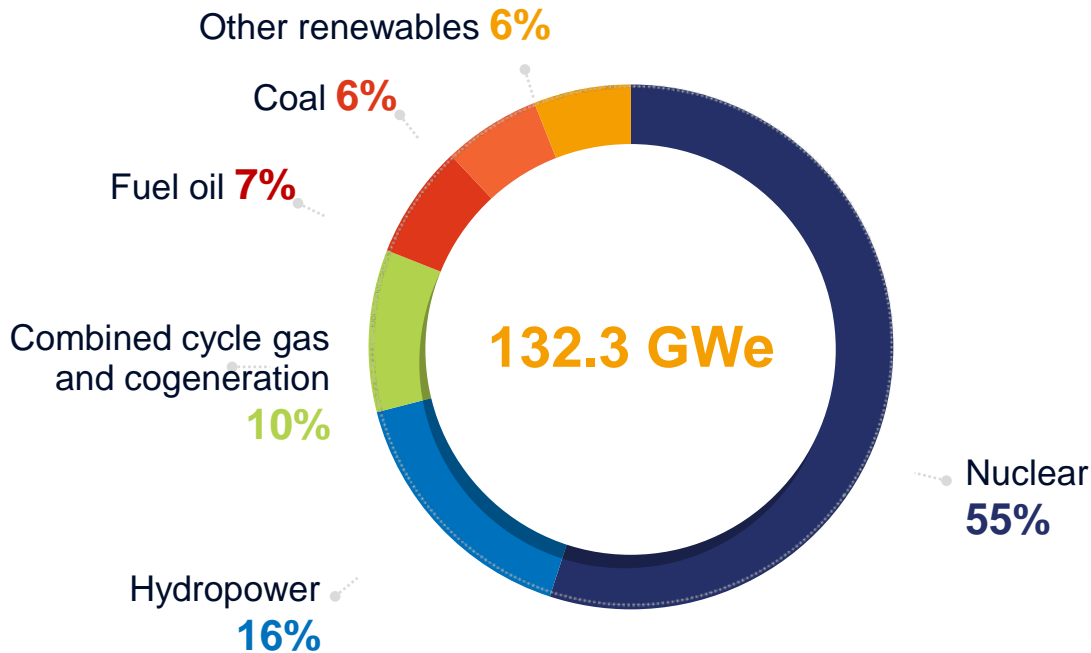

Electricity generation in TWh

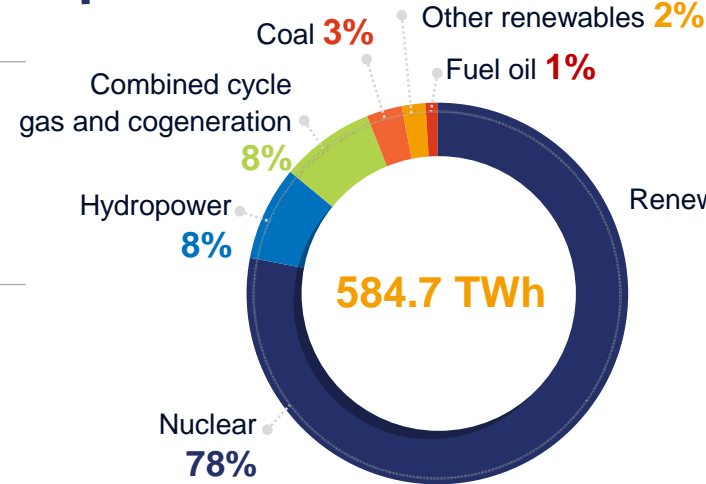

Heat generation in GWh

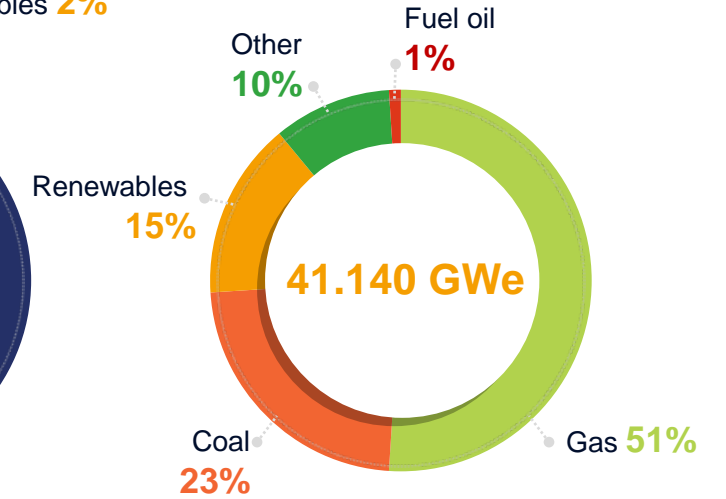

Net research and development budget

in millions of euros

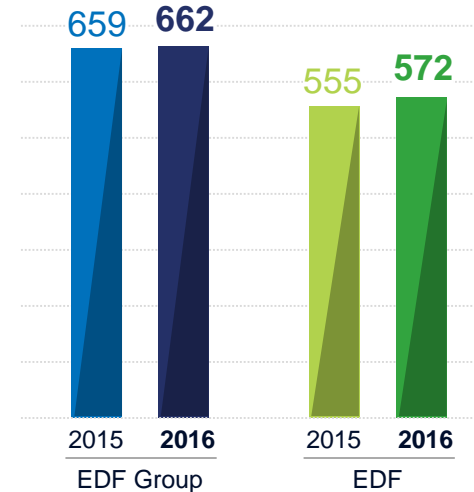

20180320_EC Workshop_LC

Fully consolidated Company data at 31 December 2016.

(1) Including Linky and new developments net of disposals.

(2) Direct emissions excluding the life cycle analysis of generating plant and fuel.

EDF HAS SET SIX CORPORATE SOCIAL RESPONSIBILITY GOALS TO UPHOLD THE UN'S 17 SUSTAINABLE DEVELOPMENT GOALS.

Its progress towards these goals will be reported each year as a sign of its commitment.

6

- 1. CLIMATE CHANGE
- 2. HUMAN RESOURCE DEVELOPMENT
- 3. FUEL POVERTY
- 4. ENERGY EFFICIENCY
- 5. DIALOGUE AND CONSULTATION
- 6. BIODIVERSITY





AGENDA

- 1 The EDF Group
- 2 Energy Audits in the Industry and Regulation
- 3 The Energy Services within EDF
- 4 Audits in the Industry
- 5 Q/A

Energy consumption in the industry in Europe

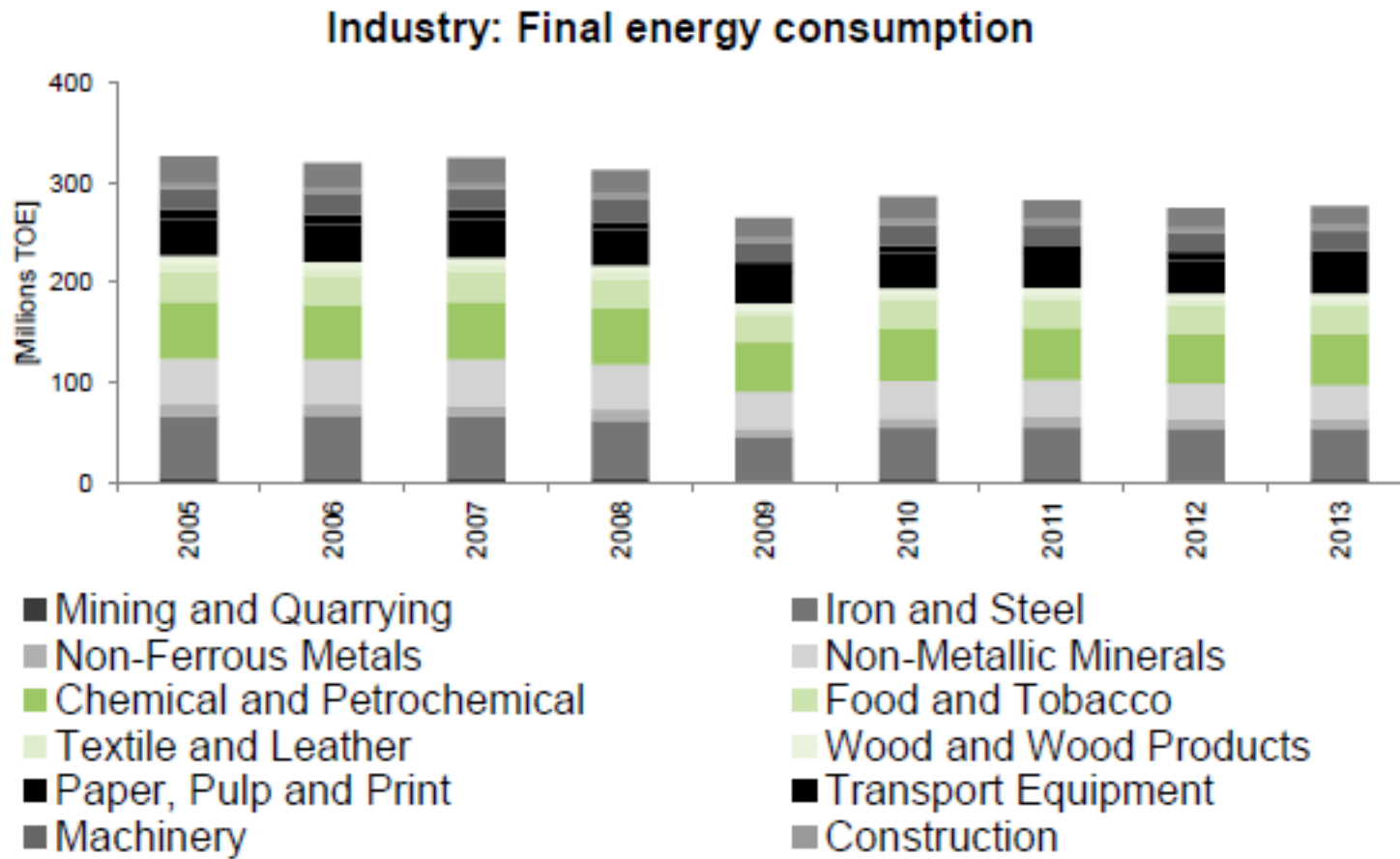

- 22%
technical
potential

- 5 to 8%
2 years
payback

Source: European Commission based on Eurostat data, ICF (2015 – ongoing)

20180320_EC Workshop_LC

EU regulatory framework

- The [Energy Efficiency Directive 2012/27/EU \(EED\)](#) is one of the core pieces of European Energy, legislation which intends to foster the increase of energy efficiency.



- [Article 8 EED](#) aims to increase the number of energy audits in [industry and the commercial](#) sector:
 - For large enterprises, mandatory energy audits are required [every 4 years](#).
 - For SME, Member States are encouraged to establish appropriate instruments to support energy audits.
- The EED entered into force in December 2012 and Member States were expected to fully transpose the Directive, including Article 8, into national legislation within a period of roughly 18 months, [by June 2014](#).
- By now, most of the European Member States have transposed Article 8 into national legislation; the level of transposition and concretization of requirements, however, varies accross Member States.

Energy Audit, a mean to reinforce industry competitiveness



Large enterprises or groups with +250 employee or +50 M€ of turnover



Mandatory energy audits **before the 14 of November of 2016**



Coverage of at least **85% of the total energy consumption**



Performed by **qualified auditors**



An alternative: Energy Management System (**ISO 50001**)



Energy Audits
starting point for improving energy efficiency and reinforcing **competitiveness**



Energy Audit as a 1. step towards EMS

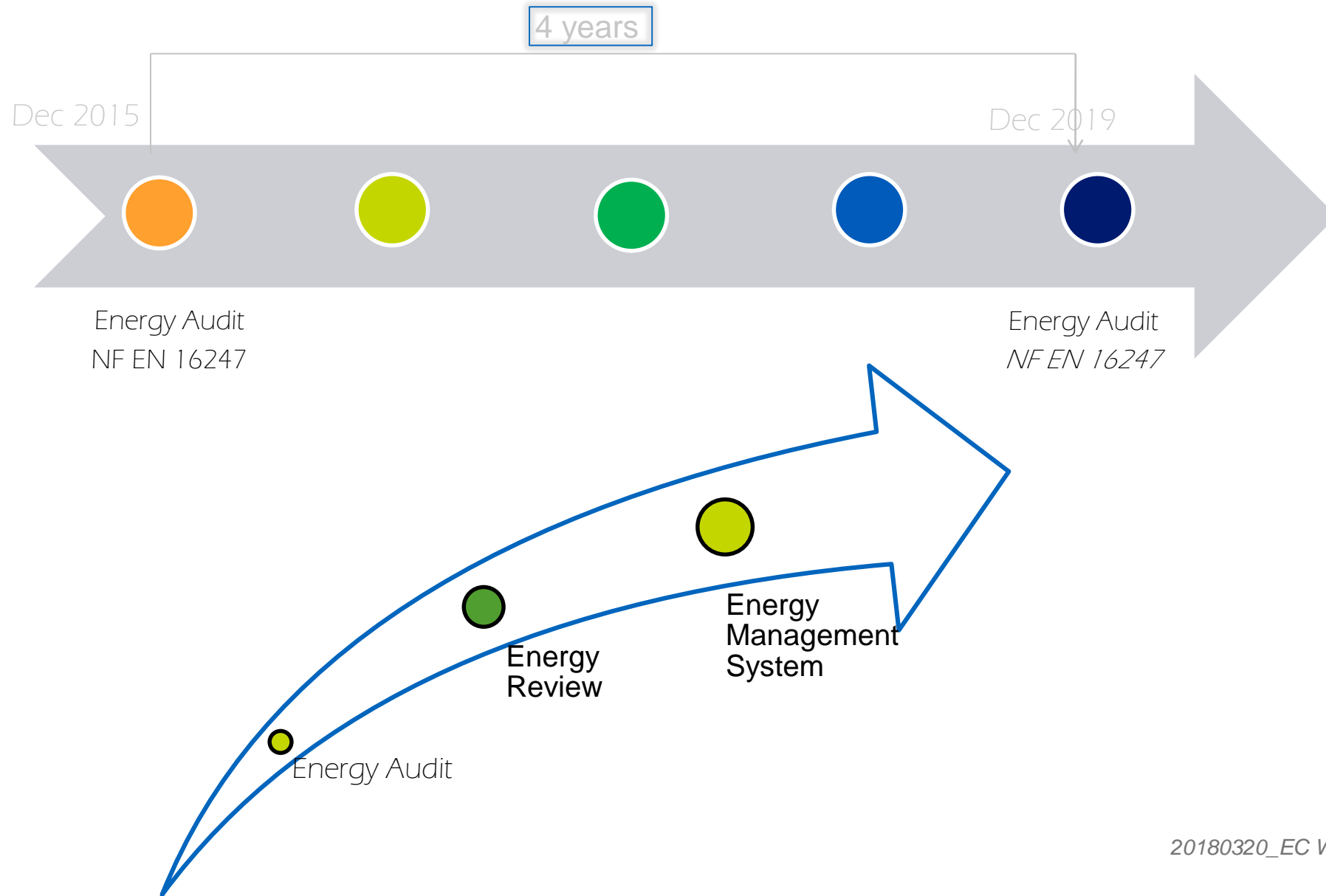



AGENDA

- 1 The EDF Group
- 2 Energy Audits in the Industry and Regulation
- 3 The Energy Services within EDF
- 4 Audits in the Industry
- 5 Q/A

CAP 2030, EDF group's transformation includes the CAP 2030 strategic programme

CAP 2030

EDF, the efficient and responsible electricity company, the champion in low-carbon growth.

CLOSER TO CUSTOMERS

Create new competitive, **decentralized** solutions, new customized **energy services** and **smart grids**

LOW CARBON PRODUCTION

Re-balance the production mix by speeding up the **development of renewable energy** and guaranteeing the **safety and performance** of existing nuclear plants and nuclear new build

INTERNATIONAL GROWTH

Expand to new geographic areas by developing our low carbon solutions in **developing countries**, while strengthening our position in Europe

EDF, A global energy management offering for the industry

EDF is accompanying its **Customers** for the development of their businesses, from greenfield locations to extension or upgrade of existing units, while ensuring access to the needed energy, in a competitive and low carbon manner:

Safe electricity (access to the public network, dedicated power generation, ...)

Optimization and management of the utilities

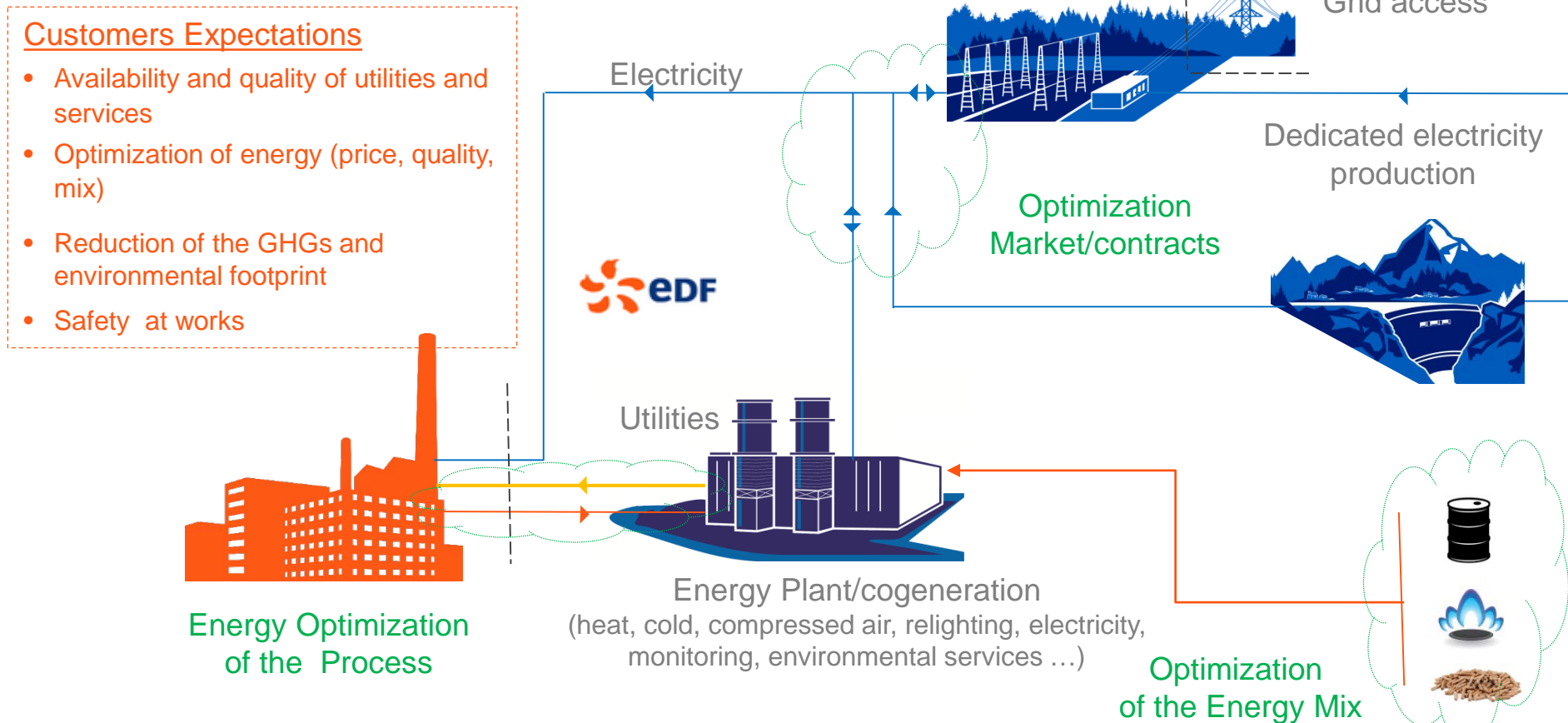





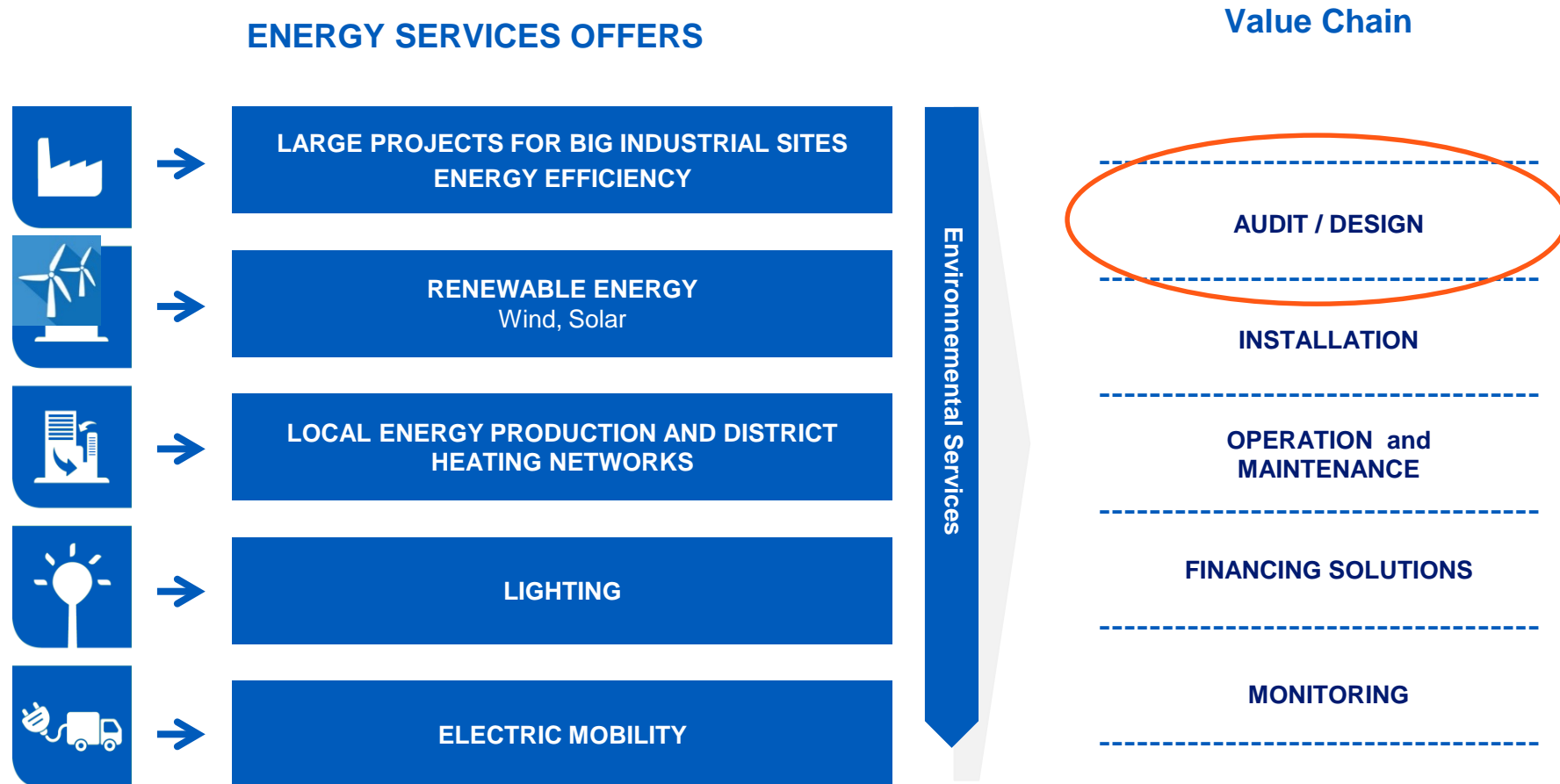

A broad range of energy services

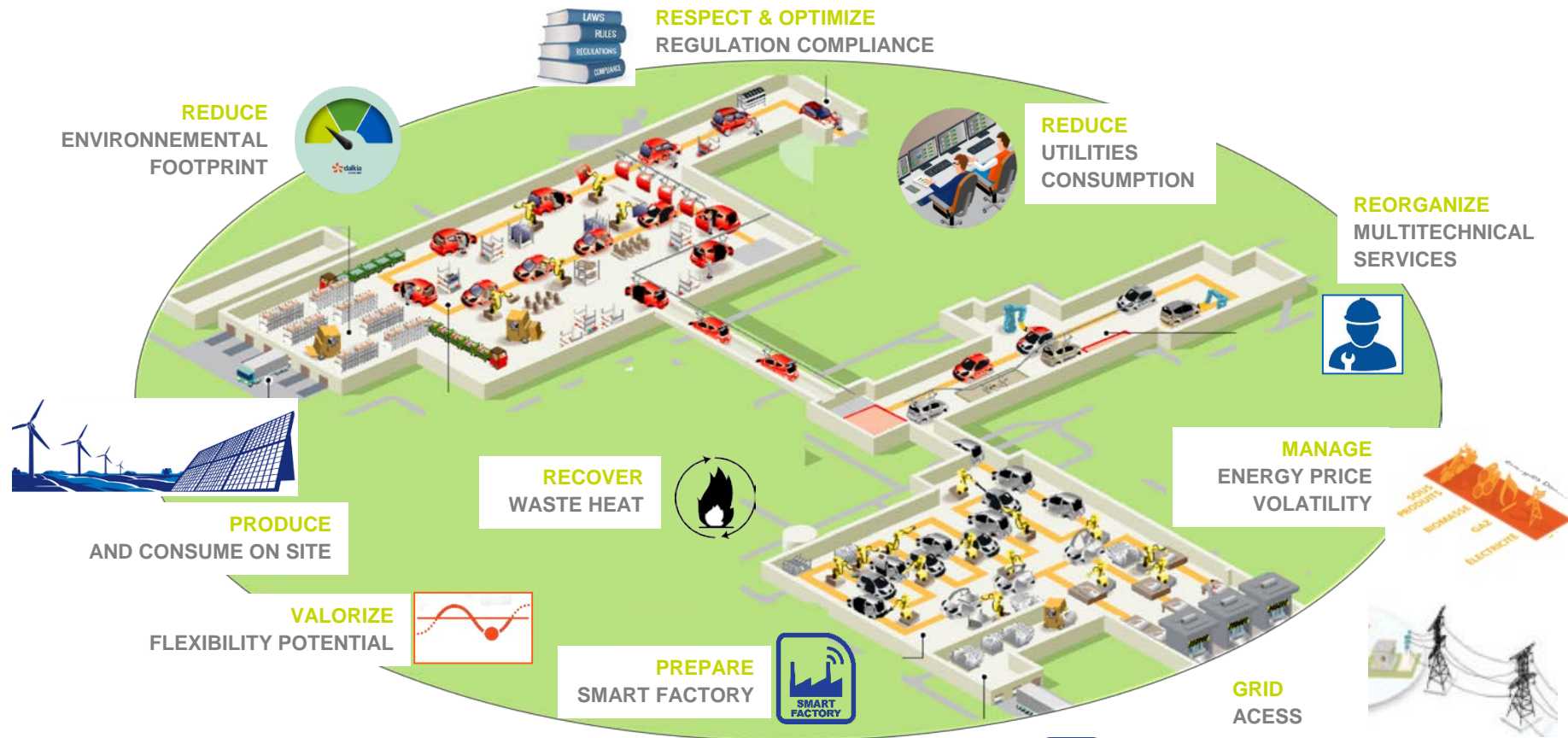
A separate Business Line with strong ambition at International level, leveraging on existing References and Products



Potential of Energy Efficiency in the industry



-  Steam, hot water
-  Process cooling, chilled water
-  Compressed air, vacuum
-  Clean rooms
-  CHP, Electricity generation
-  Water treatment, Environment

 **DEVELOP ELECTRIC MOBILITY**

Integrated offer for energy efficiency services in the industry

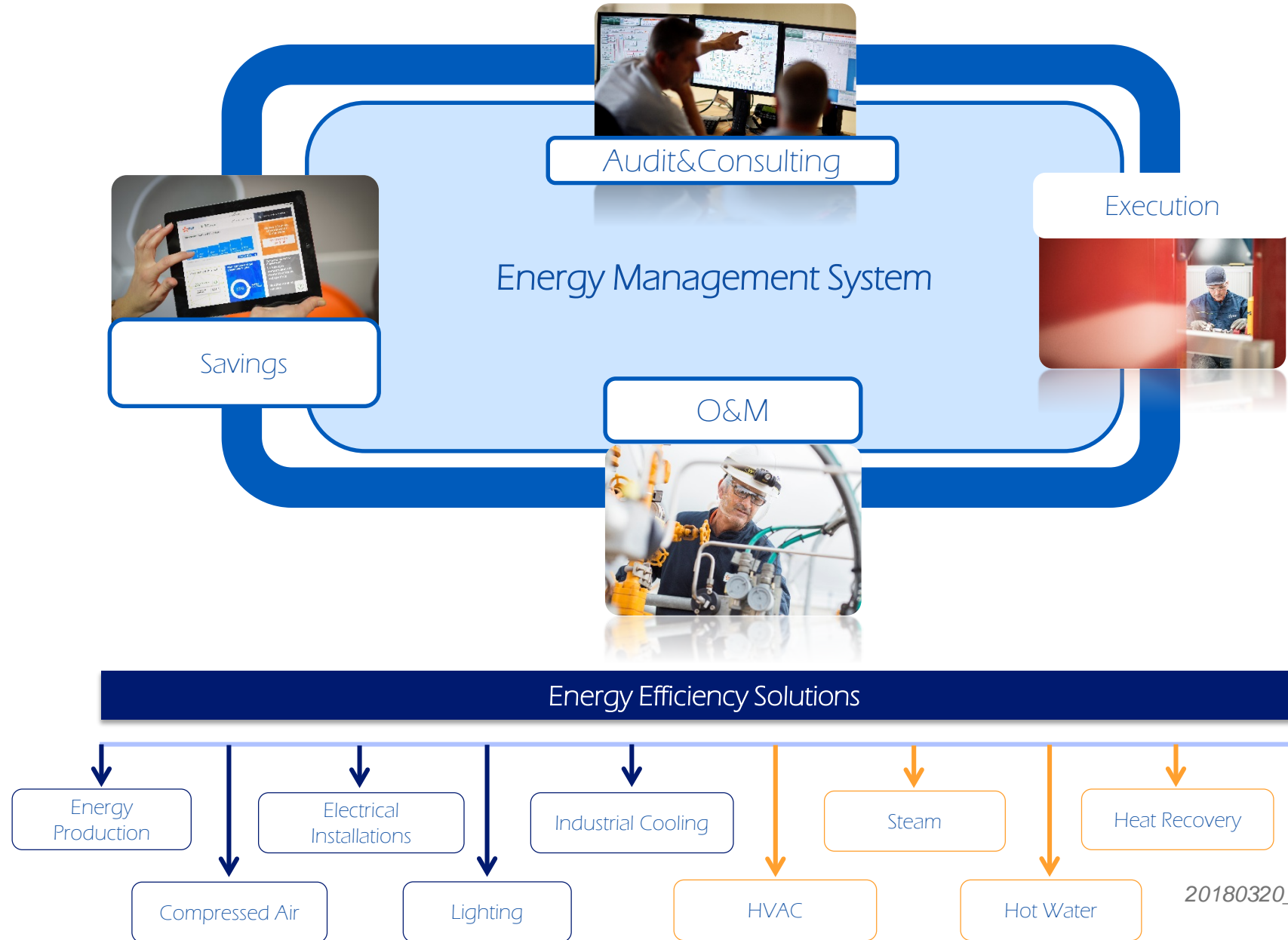



AGENDA

- 1 The EDF Group
- 2 Energy Audits in the Industry and Regulation
- 3 The Energy Services within EDF
- 4 Audits in the Industry by the EDF Group
- 5 Q/A

Types of industrial sectors most suitable for energy savings

FOOD & BEVERAGE



AUTOMOTIVE



CHEMICAL



PAPER



PHARMACEUTICAL



METALLURGY



Phases of the energy audits in the industry



Duration: between 2 and 3 months

The legislation binds large companies to present a first energy audit **before the 14th November 2016**, needed to be renewed every 4 years

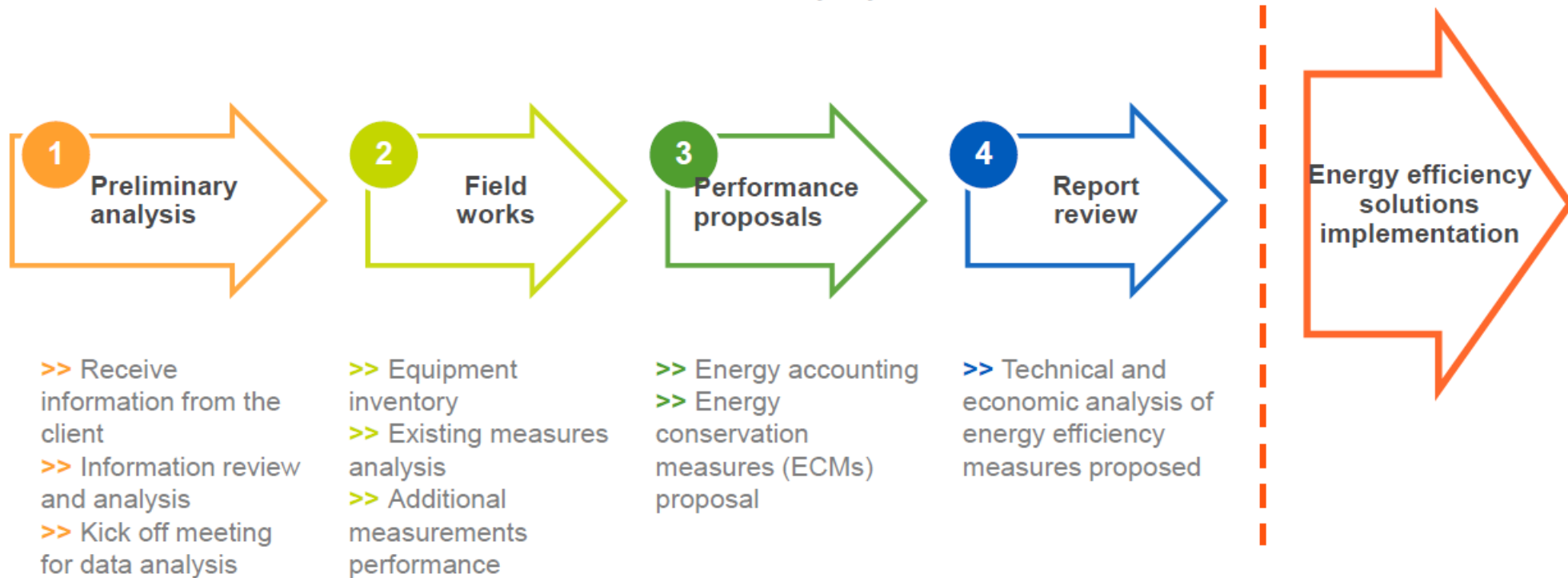

A first essential stage for **detecting potential savings and identify viable and feasible projects**

EDF Group References / Steel Industry

Variable speed drive on combustive air fan for steel industry furnace

- **Furnace:** slab furnace (60 m) of 350 tph
 - Heats the steel slabs at 1300 °C before rolling
 - With 9 temperature-regulated zones
- **Burner:** Stein – modulating per zone
- **Input data :**
 - PLC data over a representative period
 - Fans : sheets of characteristic curves unavailable (installation dating from 1983)
- **Analysis of input data :**
 - Fuel : great variability of the fuel mix's lower heating value and stoichiometric fuel/air mixture ratio → variability in the need of air (even at constant load)
 - Drift of excess air in low load
 - Load varies greatly without reaching the full load rating
 - Often functioning in low load
 - Over-dimensioned fan units
 - For the very low speeds, the vents are shutting without being able to counter the rising pressure and the leakage rates
- **Fuel :** mix of natural gas and coking gas (proportions according to availability)
- **Fans :** 2 groups (East and West) VIM of 1984 of 630 KW supplied with 3KV.

Electricity savings :

42 K€

Gas savings : 128 K€

ROI < 2 years



EDF Group References / Plastic Industry

Heat recovery from air compressors

Heat recovery from air compressors used for pre-heating water (maintaining the moulds in temperature for stand-by purposes)

EDF study

- Estimation of the energy savings,
- Block diagram of the solution, dimensioning
- Estimation of the necessary budget for the equipment,
- Estimation of the ROI
- Post installation follow-up

Installation made by EDF: In operation since July 2014

Savings : 32,9 k€
Investment : 53,5 k€
ROI = 1.6 years

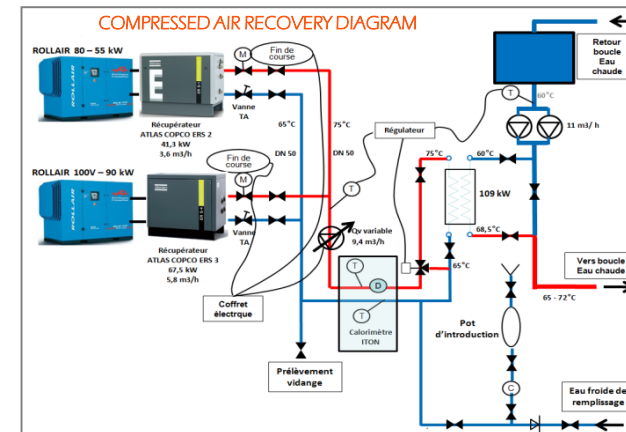
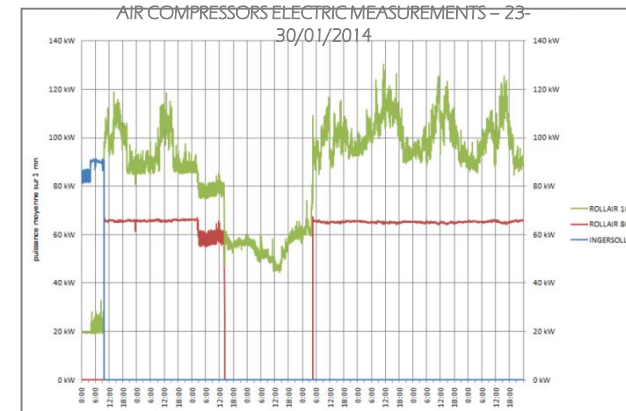

EDF Group References / Automotive sector

Chiller analysis in Paint booths

Context :

- Energy performance plan
- Cooling needs for maintaining paint-spraying booths in temperature and humidity, and cooling the cataphoresis bath
- **Objective** : Optimal performance of the chiller for winter/summer operating

Facility description :

- 3 water-cooled R134a centrifugal compressors
- 1 water-cooled R22 screw compressor
- Total cooling capacity : 13 400 kW

MEASUREMENTS :

- On the condensers and evaporators of the refrigerating units
- On the chillers' outlets
- On the cooling towers

MEASUREMENTS CONFIRMED:

The week-to-week **reproducibility**, the **oversizing** of the facility leads to excessive consumption, **the reduction of the chilled water flows** by increasing the ΔT on the loop, the **control** of the existing speed variators, the **design** of the refrigerating unit replacing the R22 device, the regulation of the condensing temperature in order to **prevent** the refrigerating units from operating with a partial load, the **electronic variable speed drive detection** on some outlets dedicated to the process cooling, the recommendations on the **maintenance** of equipments.

EDF Group References / Industry

Energy Management System

Measurement plan, definition of the energy performance indicators, software for analysis and monitoring fluid consumption, reference models, analysis between production and energy use.

EDF is supported by its partnership with the certification institute AFNOR which allows us to provide customer support for the ISO 50001. In this context French CEE certificates thus generated may then increase by 100% if Certification Level 2 is reached.



AGRI FOOD INDUSTRY- AERONAUTICS INDUSTRY- PAPER MILLS

REFERENCES

- Methodological support for ISO 50001 certification
- MAPE Energy Software Analysis

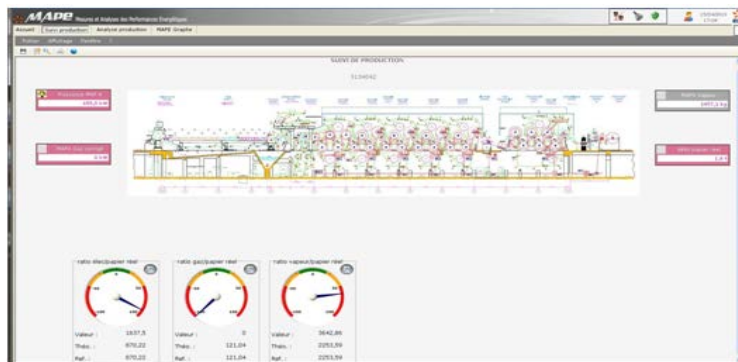

EDF Group References / Audit on Lighting Industry

→ WHAT IS LIGHTING SERVICE DELIVERY ?

The study "lighting" is a service of expertise offering solutions optimized in terms of visual comfort, energy consumption, maintenance and operation of light equipment.



Insured by the Eco Eclairage agency of EDF, which is composed of 4 experts spread over French territory, the study is carried out in compliance with the labor code and the standards in force (NF EN12434-1 and 12464-2) As well as the recommendations of the AFE (French Association of Lighting).

This expertise is aimed at major industrial companies. It is always done in order to optimize the productivity of these companies while taking into account the safety of employees.

→ CARRYING OUT STUDIES

The lighting offering involves carrying out audits of existing installations and proposing the most appropriate lighting solutions. The different stages of this process are:

- The night visit for the photometric survey,
- The diagnosis of working conditions,
- The photo report,
- Analysis of existing equipment,
- The recording of the constraints of use (management, working time, contribution of natural light, pollution of spaces ...).

The expertise will cover all the customers' needs for the renovation of its various work and / or hospitality areas such as:

- The production halls,
- Workshops, clean rooms,
- Paint booths,
- Quality control rooms,
- Indoor and outdoor storage areas,
- The offices
- Access roads for public lighting

→ Tools used in conducting audits:

- Light meter Minolta T-10 ou T-20 (colorimeter)
- Luminance meter Minolta LS100 with through-the-lens sighting
- Numeric camera
- A laser rangefinder
- Dialux
- Vidéophoto meter

→ DELIVERABLES



A report containing the state of play, the photometric study and futur prospects for energy savings (in k € and CO2) is given to the customer.

→ DIRECT THE CLIENT

On the basis of the audit, the client is directed towards the use of high-performance equipment in relation to its constraints of use and financing capacities. This may include:

- The optimization of the number of luminaires (reduction of maintenance costs),
- The energy efficiency of torque lamps and auxiliary power,
- The reduction of the unit power per luminous point,
- The choice of sources very long life,
- The management of lighting (daylight, intermittence),
- Maintenance,
- Adapted LED solutions.



→ THE STUDY INCLUDES

The final study delivered to the client includes:

- The recall of the regulatory and normative requirements (EuP Directive, Grenelle II, the decree of 3 May 2007 ...)
- The technological watch (LED),
- Photometric calculation using the Dialux simulation software,
- The layout of the luminaires,
- Energy balance,
- The comparative analysis of technical solutions and installation system,
- The calculation of operating and maintenance costs,
- The investment estimate and its time to return on investment,
- The environmental balance expressed in tonnes of CO2,
- Estimates of energy savings certificates (kWh cumac).

→ POSSIBLE OPTIONS

The options allow you to go further in this service. They are reflected in the search for the maintenance of existing facilities, the testing of new technologies and the carrying out of surveys aimed at improving the working environment by providing visual comfort for employees. The services offered are as follows:

- A technical specifications of maintenance of the installations,
- A reception inspection of the installation by carrying out photometric measurements at commissioning one year after the date of operation,
- Measurements of consumed, active and reactive electrical power and the determination of the harmonics of the installation,
- Tests of luminaires with LED sources (according to the matrices of maturity of the union of lighting),
- A set of specifications for consulting companies.
- Study of the luminaires at the EDF des Renardières laboratory,
- Study of Lifi projects (communicating light).

EDF Group Innovation / Cement Industry

High-efficiency motorization

2/3 of the electricity consumed by industrial customers is used to power electric motors

Design studies, dimensioning of the installation, electricity consumption reduction through installation of a variable speed drive system and/or permanent magnet motors. Study of an optimized drive system. Management of intermittences. Assistance for preventive maintenance of the motors.

Innovation – in experimentation

EDF R&D has developed a new system called « MotorBox » allowing to manage easily, in a single plant, a group of electric motors linked to driven machines (pumps, ventilators,...). From a single current transducer we may follow from distance (use of GSM) the energy consumption, the total functioning time, the average load and the number of engine starts.



REFERENCES

Cement Plant

- Centralization and optimization of compressed air generation by implementation of Variable Speed Drive compressors
- Reduction of cooling fans power consumption by VSD
- Installation of permanent magnet motors on conveyor belts



- 220 motors audited
- 120 electric motors monitored
- 6% of energy savings with motor replacement solution
- 15% of energy savings with variable speed drive solution

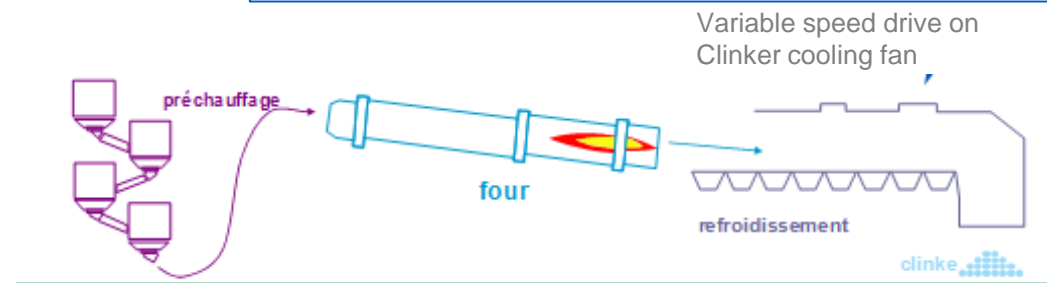

Access to information/data is key for energy transition

- The main issue for energy efficiency measures in the Industry, large or SMEs: the investment that is necessary for measuring indicators.
- 3 developments are currently being explored or deployed by EDF:
 - Non intrusive sensors
 - Communication Protocol for gathering measurements / data
 - “Audit toolkit” allowing data communication by 4 G network
- New products development at the R&D:
 - Phoenix
 - Smart Factory

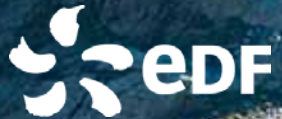

Thanks for your attention

Mrs Liliane CLOÂTRE

EDF International Division

Liliane.cloatre@edf.fr